

MANUAL DE MONTAJE

A2H



MAMPARA ANGULAR DE DUCHA

1 HOJA CORREDERA + 1 FIJA

A2H

1

PRESENTAMOS PERFIL "U" DE FIJO, EN PARED, NIVELANDOLO, A 3 MM. DEL BORDE DEL PLATO DE DUCHA Y MARCAMOS TALADROS.

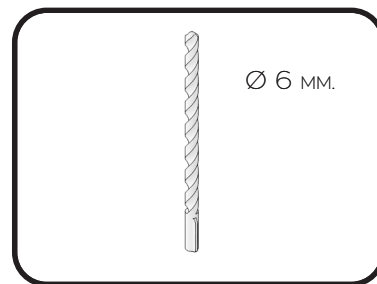
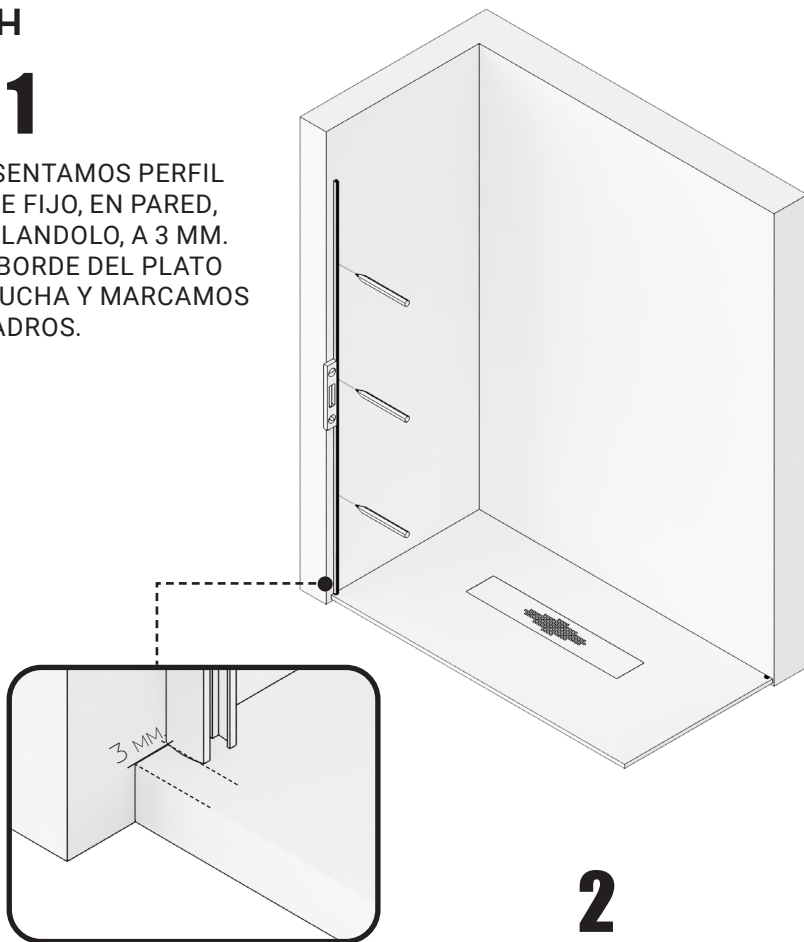

2

TALADRAR LA PARED CON BROCA DE 6MM.

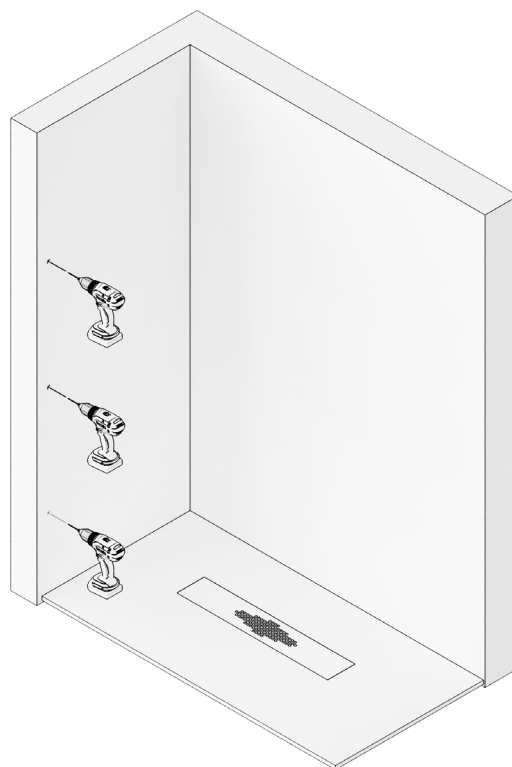

3

ATORNILLAR EL PERFIL "U" A PARED, FIJANDOLO CON TACOS DEL N° 6 Y LOS 3 TORNILLOS 4.2X32.

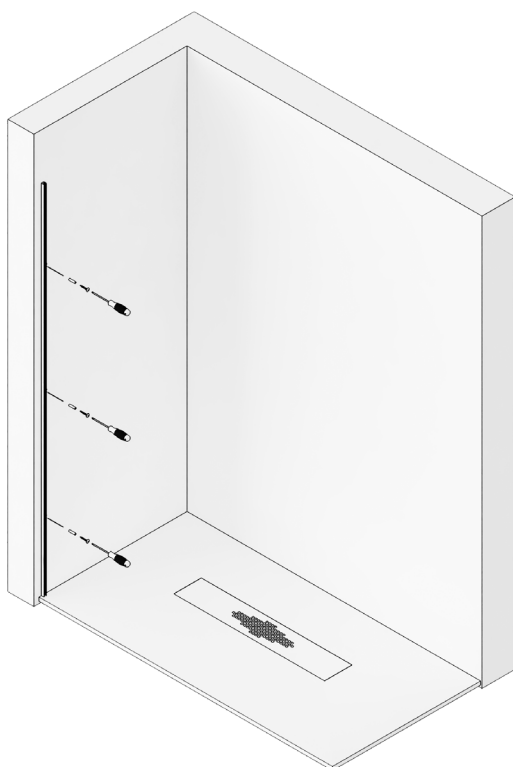

4

COLOCAMOS GOMA DE ESTANQUEIDAD INFERIOR EN LA HOJA FIJA E INTRODUCIMOS EL VIDRIO EN LA "U", APOYÁNDOLO SOBRE ESTA.

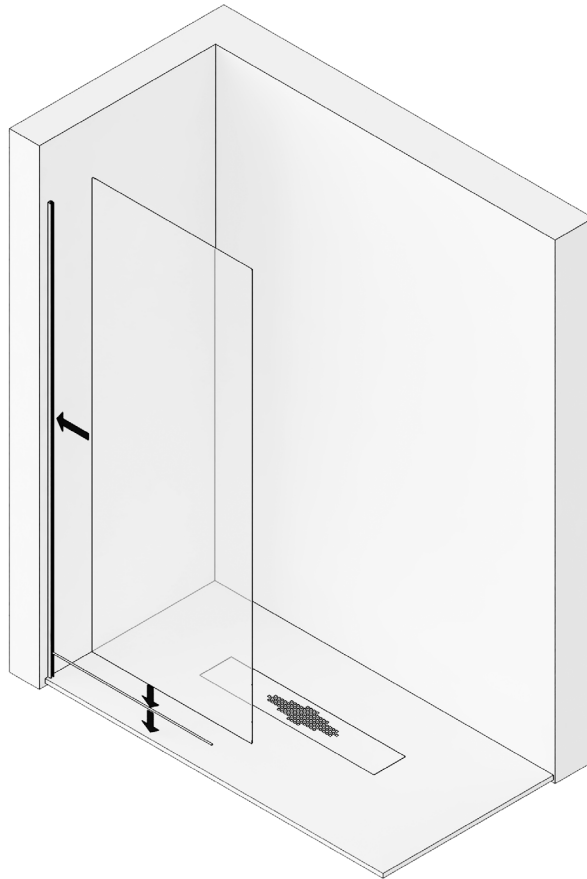

5

COLOCAR LA PINZA GUIA INFERIOR EN EL EXTREMO DEL VIDRIO FIJO, MONTÁNDOLA PREVIAMENTE SEGÚN CORRESPONDA SU POSICIÓN.



MONTAJE PINZA GUIA INFERIOR

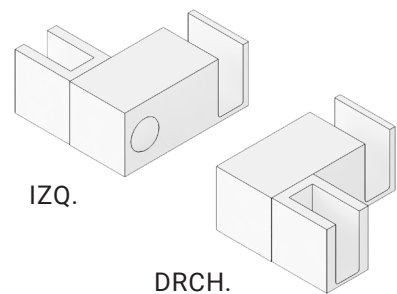
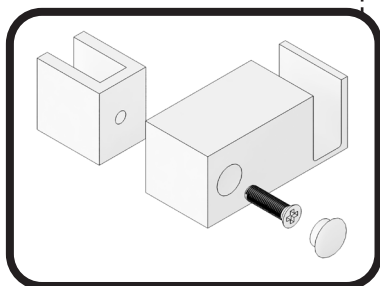

A2H

6

PRESENTAR GUÍA SUPERIOR CON VASOS Y CODO UNIÓN, FIJÁNDOLO CON SUS TORNILLOS AUTOROSCANTES, SOBRE EL VIDRIO FIJO, NIVELAR Y MARCAR LOS TALADROS.

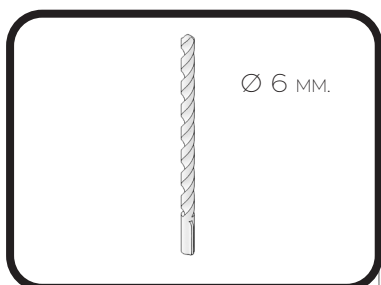
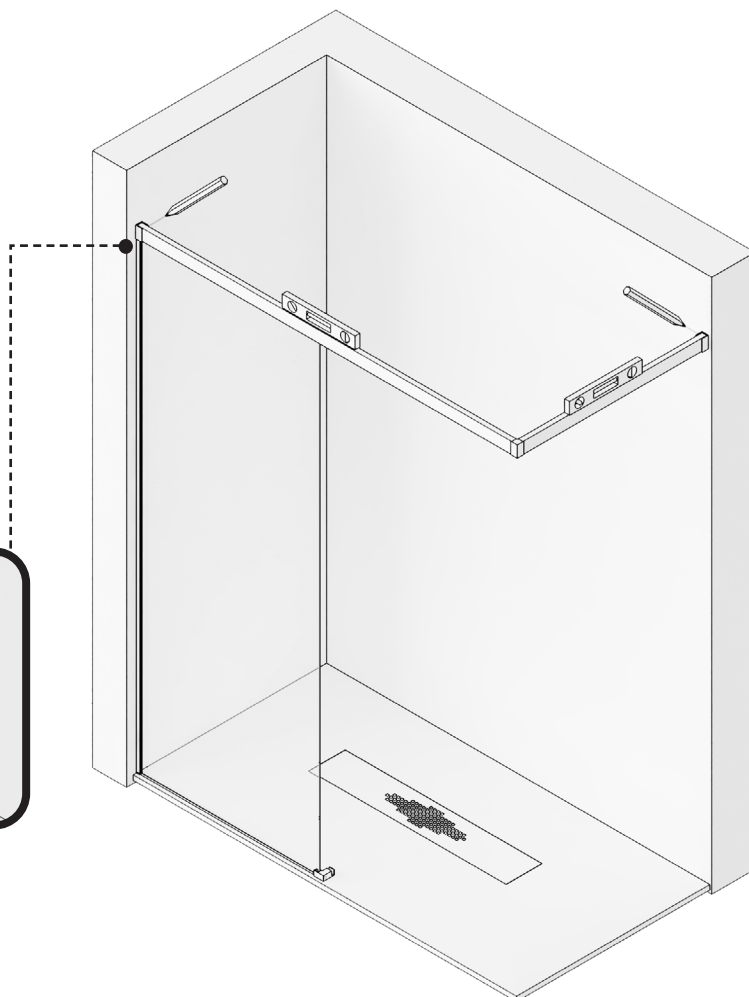
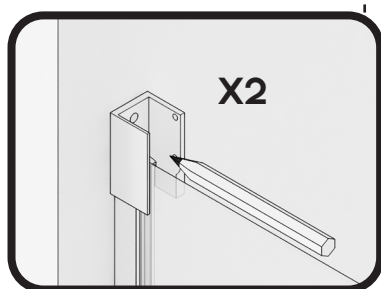

7

TALADRAR LA PARED CON BROCA DE 6MM.

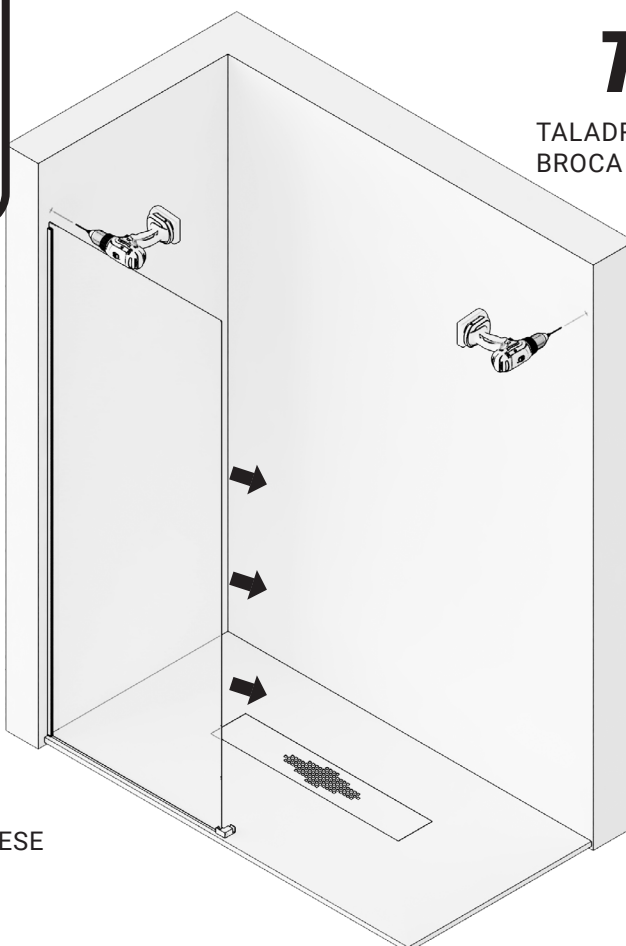

RETIRAR CRISTALES FIJOS SI FUESE NECESARIO.

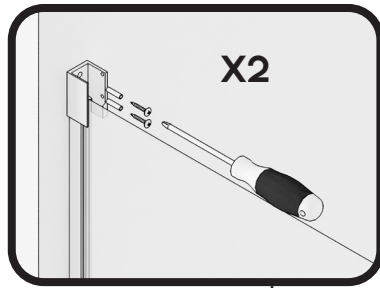

8

ATORNILLAR LOS VASOS SOPORTE GUÍA SUPERIOR A PARED

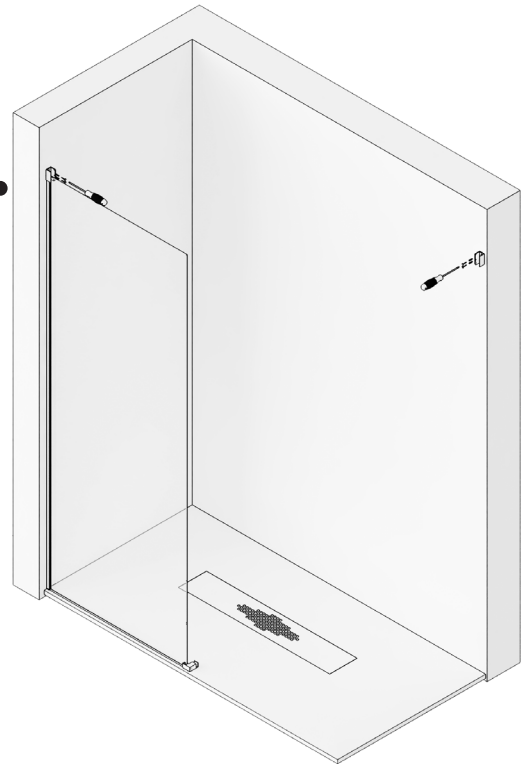

9

INTRODUCIR LOS 2 TOPES FRENO EN LA GUÍA SUPERIOR FRONTAL, DESPLAZÁNDOLO UNO HACIA EL FINAL DE LA HOJA FIJA Y OTRO AL VÉRTICE, COLOCAR LA GUÍA SUPERIOR UNIDA, EN LOS VASOS COGIDA A PARED Y FIJAR LA COGIDA A LA GUÍA MEDIANTE LOS TORNILLOS PRISIONEROS CON LLAVE HALLEN. ENGOMAR CRISTAL FIJO A PERFIL PARED Y A GUÍA SUPERIOR.

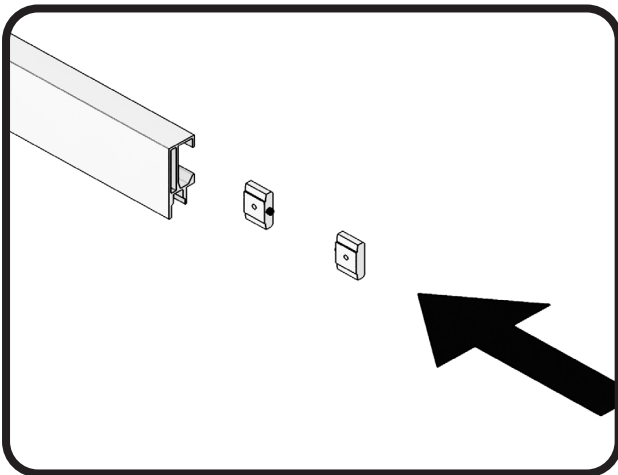

10

MONTAR CONJUNTO RUEDAS, GRADUADAS EN SU ALTURA MÁXIMA Y GOMA INFERIOR VIERTEAGUAS EN LA HOJA CORREDERA.

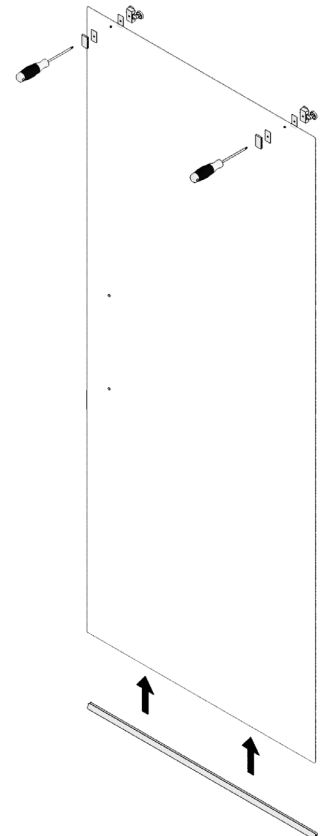

ALTURA MÁXIMA

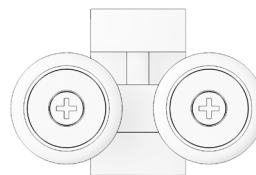

ALTURA MÍNIMA

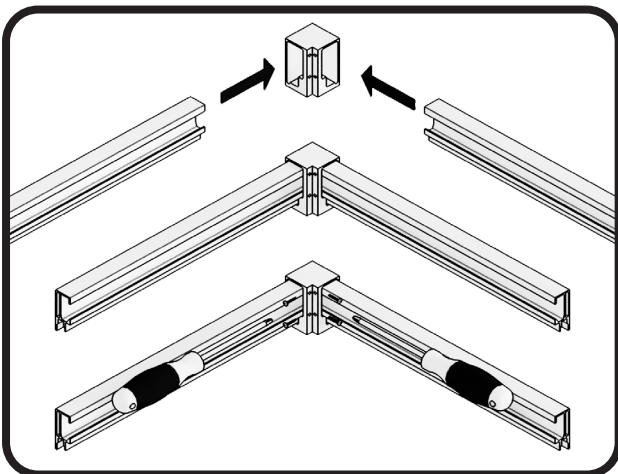
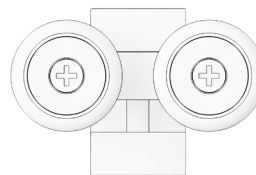

A2H

11

COLGAR LA HOJA CORREDERA EN LAS GUIA SUPERIOR FRONTAL, INTRODUCIENDO EL CONJUNTO RUEDAS EN LA MISMA Y EN LA PINZA GUIA INFERIOR, GRADUANDO EN ALTURA Y NIVELANDO LA HOJA CORREDERA, HACIENDO DESCENDER LA HOJA MEDIANTE LOS TORNILLOS DE REGULACION DE RUEDAS, CON UN DESTORNILLADOR.

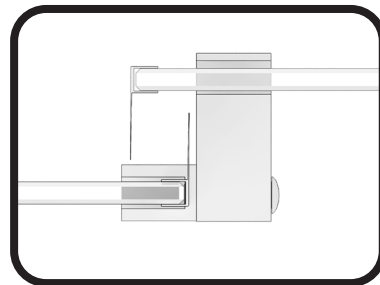
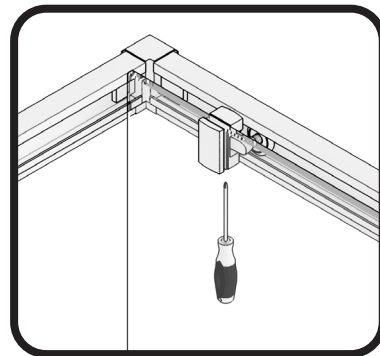
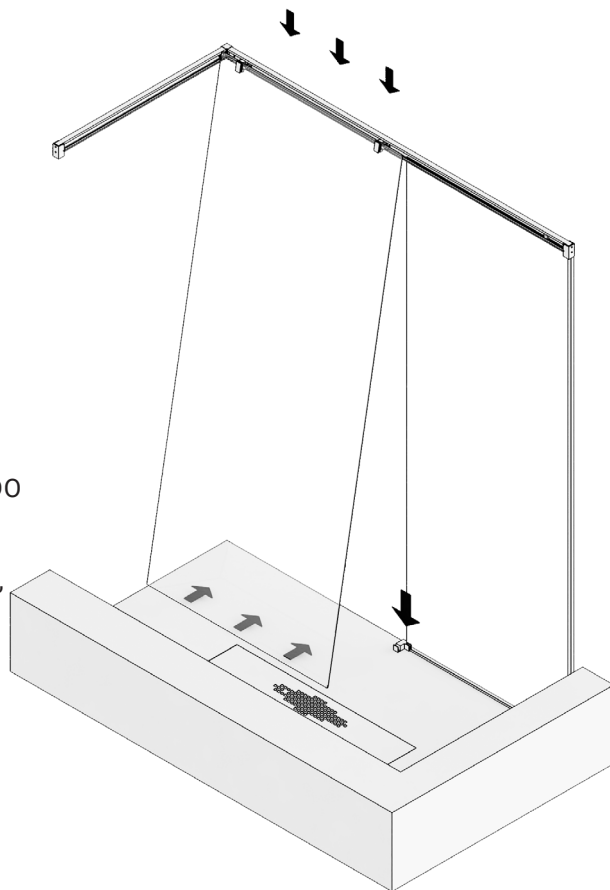

12

COLOCAMOS LAS GOMAS ALA DE CRUCE, UNAS EN EL FIJO Y OTRA EN LA HOJA CORREDERA. COLOCAR EL ASA TIRADOR.

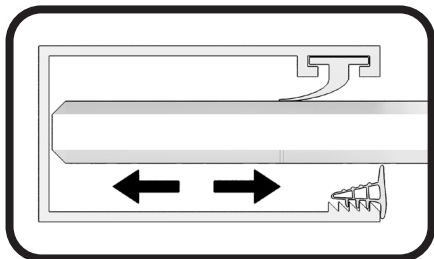
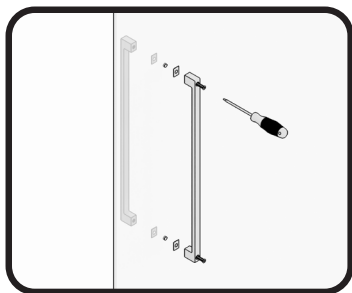

AJUSTAR EL JUEGO DE LOS VIDRIOS FIJOS SEGÚN NECESIDAD. FIJAR EL VIDRIO, ENGOMANDO EL CRISTAL CON EL PERFIL A PARED Y CON LA GUIA SUPERIOR.

13

FIJAR LOS TOPE FRENO EN SU POSICIÓN, MEDIANTE SUS TORNILLO PRISIONERO.

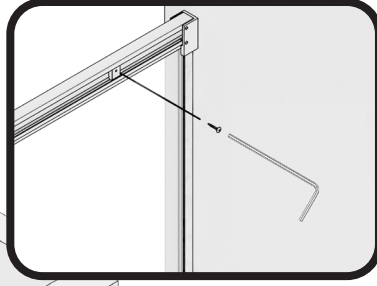

14

MEDIMOS, CORTAMOS, MONTAMOS SUS TAPONES Y PEGAMOS EL PERFIL DE ESTANQUEIDAD, DE PINZA INFERIOR AL CODO DEL VERTICE, POR DELANTE DE LA HOJA CORREDERA Y DE ESTE A PARED.

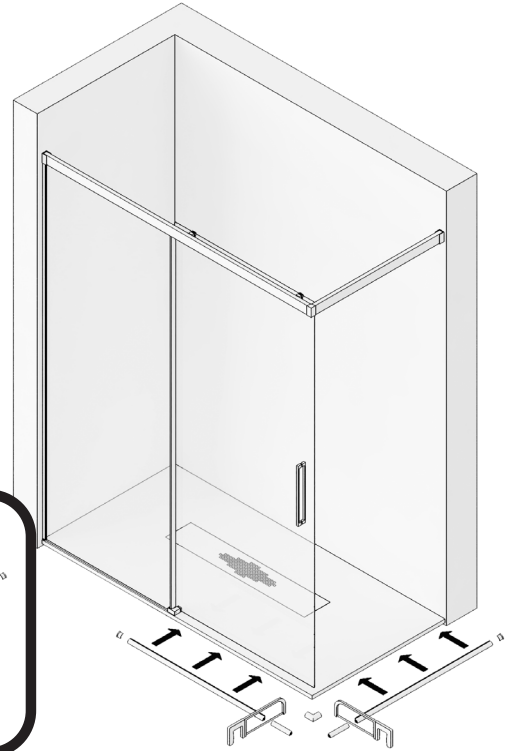
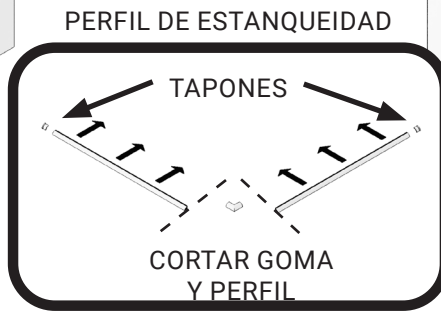
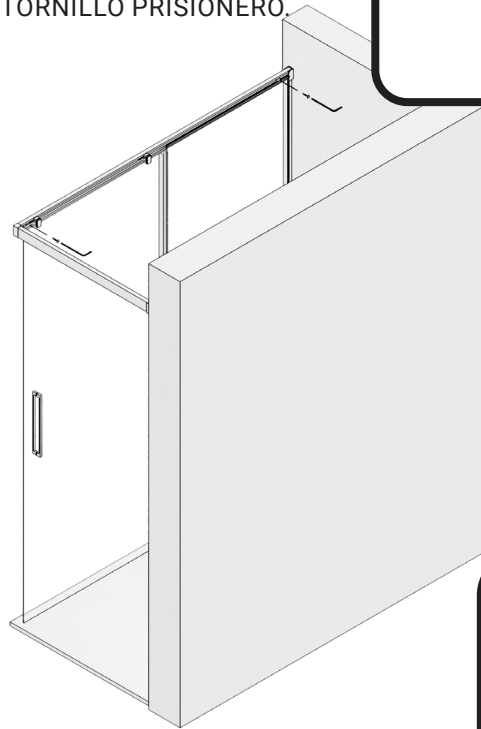

15

SELLAR CON SILICONA EL CONTORNO EXTERIOR DE LA MAMPARA.

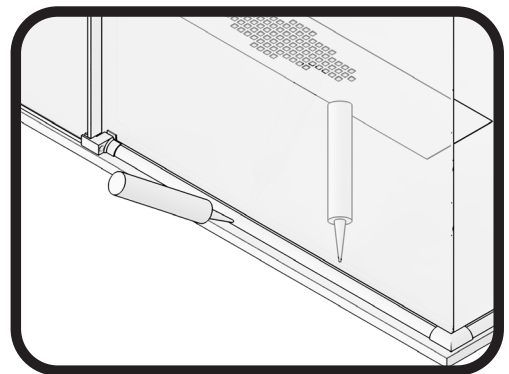

A2H

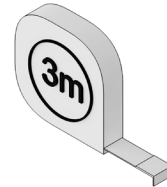
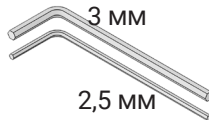
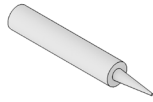
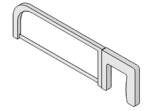
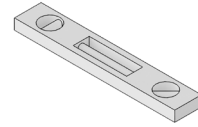
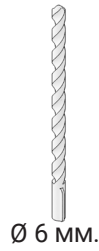
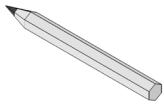

1X

HOJA FIJA



1X

HOJA CORREDERA

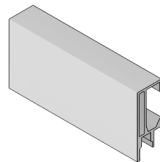

2X

GUÍA SUPERIOR



1X

CODO UNIÓN GUÍA

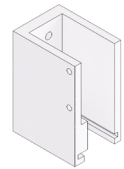

2X

VASO O SOPORTE GUÍA

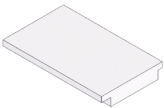

1X

TAPA EMBELLECEDORA VASO
SOPORTE GUÍA

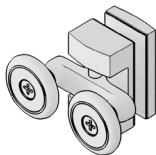

2X

RODAMIENTO SUPERIOR
DOBLE TAMDEN

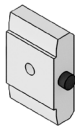

2X

TOPE FRENO

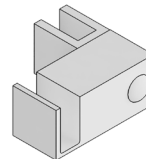

1X

GUÍA PINZA INFERIOR



2X

ASA TIRADOR

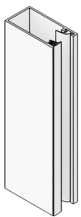

1X

PERFIL "U" FIJO A PARED

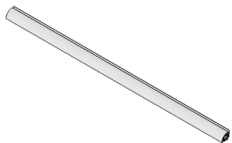

1X

PERFIL DE ESTANQUEI-
DAD



1X

TERMINAL PERFIL
VIERTEGUAS

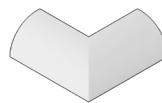

1X

CODO PERFIL ESTAN-
QUEIDAD



1X

GOMA INFERIOR
VIERTEGUAS PUERTA



1X

GOMA ESTANQUEIDAD
INFERIOR FIJO



2X

GOMAS DE ALA CRUCE

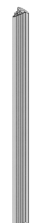

2X

GOMA CUÑA FIJACION VIDRIO



7X

TACOS Nº 6

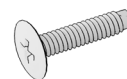

7X

TORNILLOS 4.2 X 32

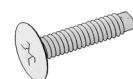

2X

TORNILLOS AUTORROSCANTE
3.5 X 9.5

fabricación
nacional