

MANUAL DE MONTAJE

F4



MAMPARA FRONTAL DE DUCHA

2 HOJAS CORREDERAS + 2 FIJAS

F4

1

PRESENTAMOS PERFILES "U" DE FIJO, EN PAREDES, NIVELANDOLOS A 3 MM. DEL BORDE DEL PLATO DE DUCHA Y MARCAMOS TALADROS.

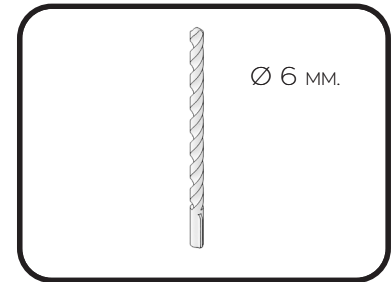
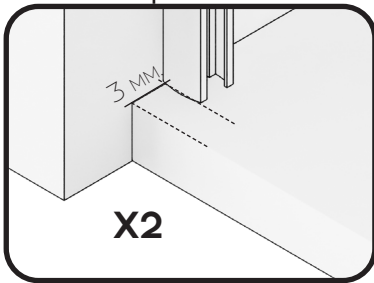
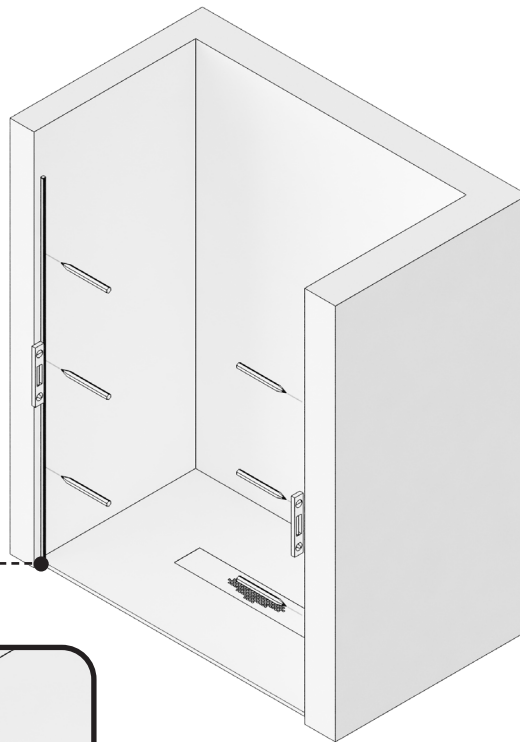

2

TALADRAR LAS PAREDES CON BROCA DE 6MM.

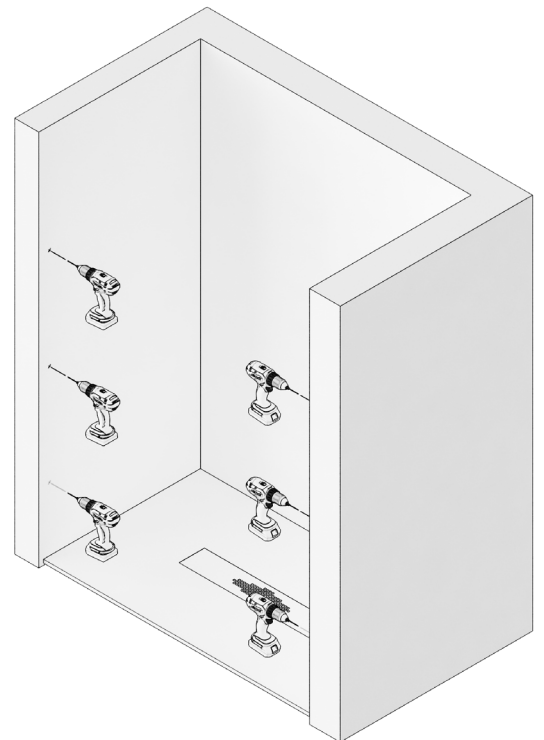

3

ATORNILLAR LOS PERFILES "U" A PAREDES, FIJANDOLOS CON TACOS DEL N° 6 Y LOS 6 TORNILLOS 4.2X32

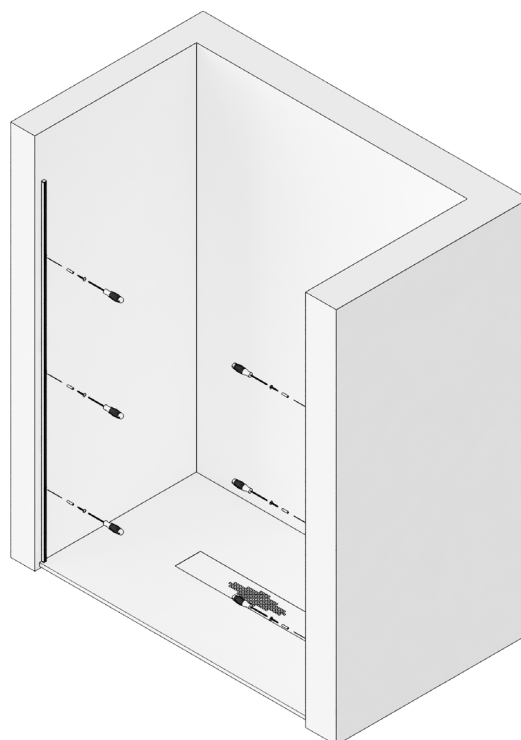

4

COLOCAMOS GOMAS DE ESTANQUEIDAD INFERIOR EN LAS HOJAS FIJAS E INTRODUCIMOS LOS VIDRIOS EN LAS "U", APOYÁNDOLOS SOBRE ESTA.

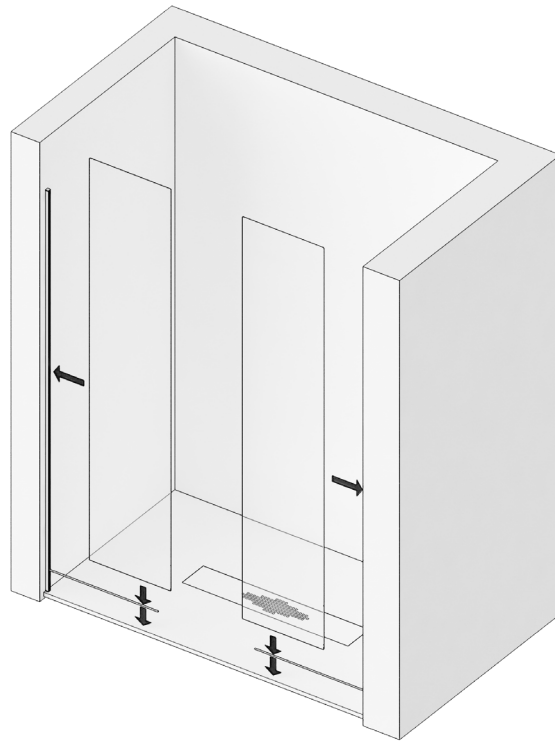

5

COLOCAR LAS PINZA GUIA INFERIOR EN LOS EXTREMO DE LOS VIDRIOS FIJO, MONTANDOLAS PREVIAMENTE SEGÚN CORRESPONDA SU POSICIÓN.

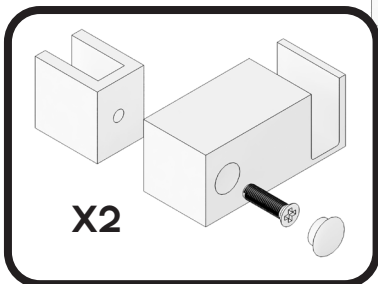
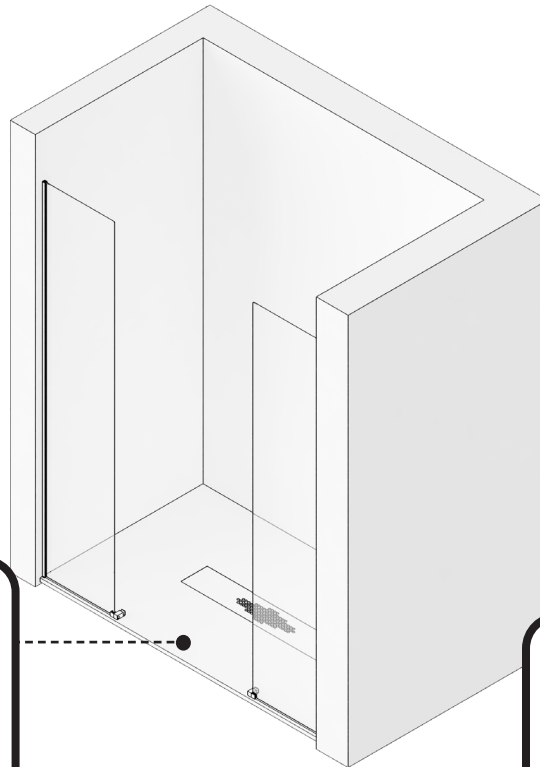

MONTAJE PINZA GUIA INFERIOR

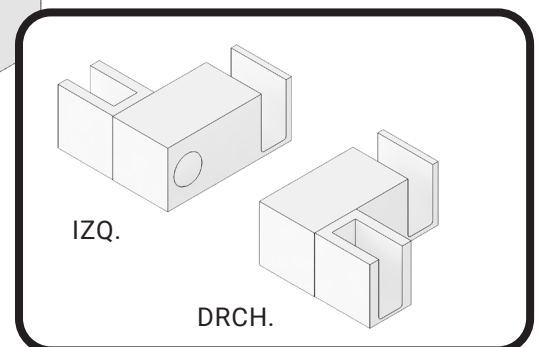

F4

6

PRESENTAR GUÍA SUPERIOR CON VASOS SOBRE LOS VIDRIOS FIJOS, NIVELAR Y MARCAR LOS TALADROS.

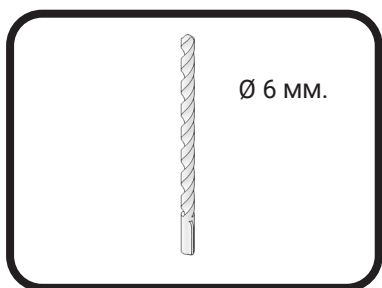
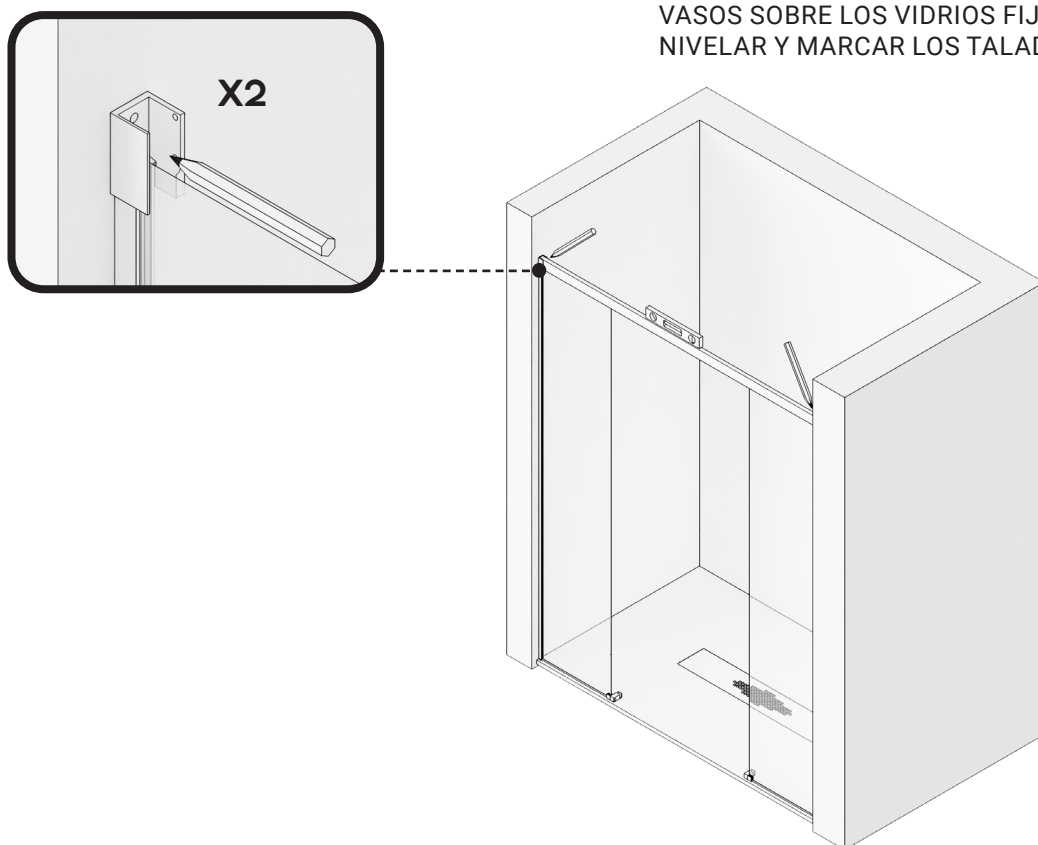

7

TALADRAR CON BROCA DE Ø 6 MM.

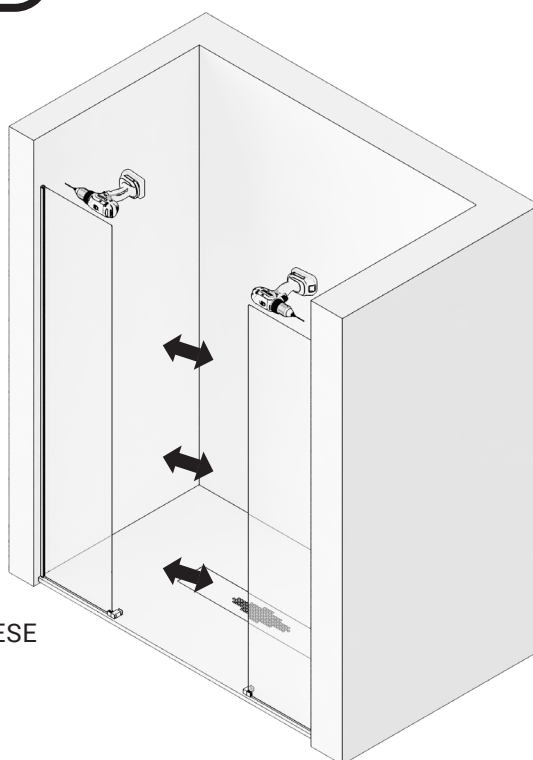

RETIRAR CRISTAL FIJO SI FUESE NECESARIO.

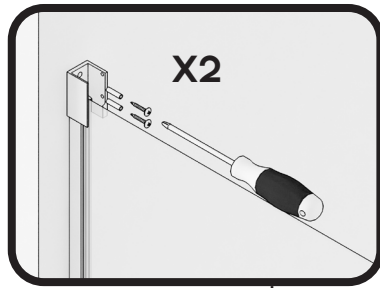

8

ATORNILLAR LOS VASOS SOPORTE GUÍA SUPERIOR A PARED.

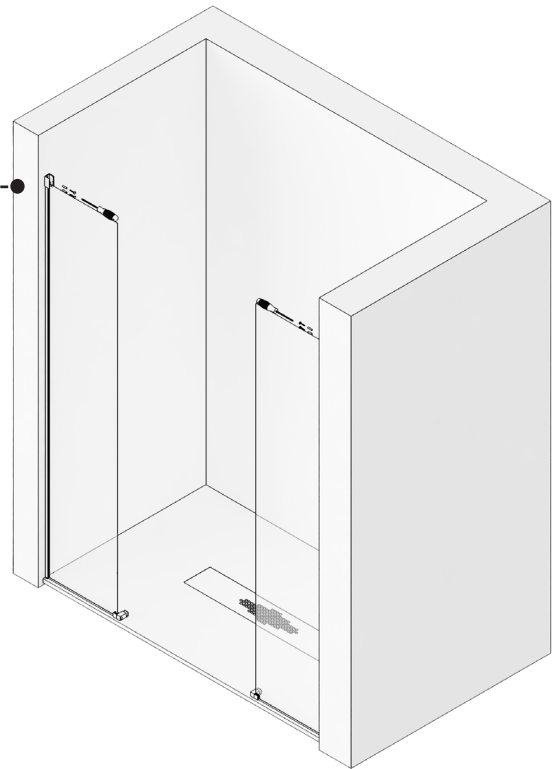

9

INTRODUCIR LOS 4 TOPES FRENO EN GUIA SUPERIOR, DESPLAZANDO 2 HACIA EL FINAL DE LAS HOJAS FIJAS Y OTROS 2 EN EL CENTRO, COLOCAR LA GUIA SUPERIOR EN LOS VASOS COGIDA A PARED Y FIJAR LA COGIDA A LA GUIA MEDIANTE LOS TORNILLOS PRISIONEROS CON LLAVE HALLEN. ENGOMAR CRISTALES FIJO A PERFILES PARED Y A GUÍA SUPERIOR.

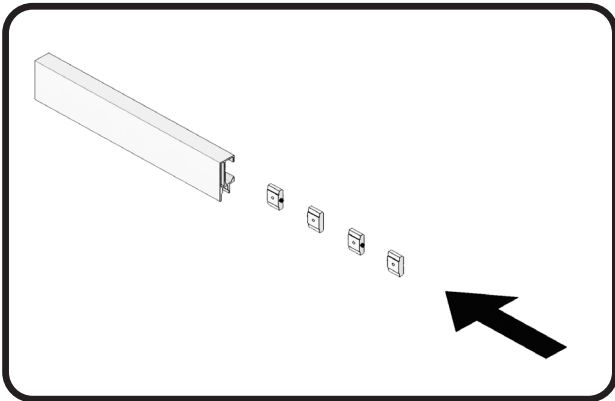

10

MONTAR CONJUNTO RUEDAS, GRADUADAS EN SU ALTURA MÁXIMA Y GOMAS INFERIOR VIERTEGUAS EN LAS HOJAS CORREDERAS.

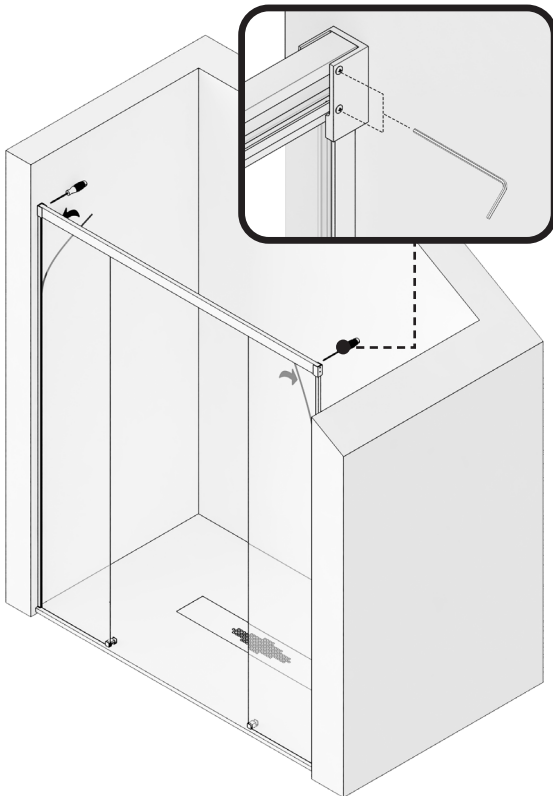

ALTURA MÁXIMA

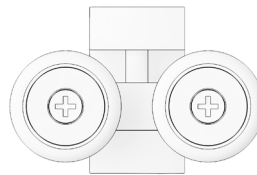

ALTURA MÍNIMA

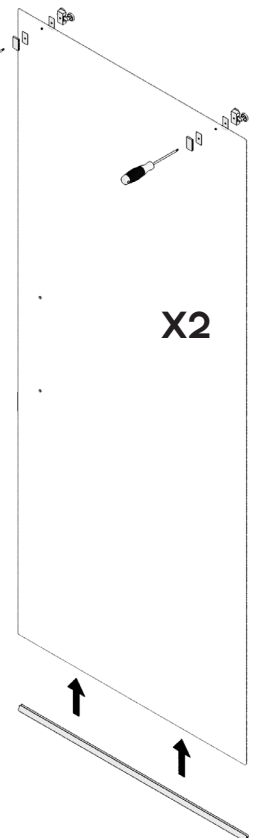
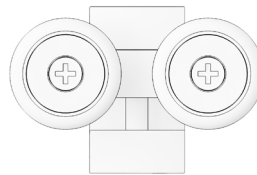

11

COLGAR LAS HOJAS CORREDERAS EN LA GUIA SUPERIOR, INTRODUCIENDO EL CONJUNTO RUEDAS EN LA MISMA Y EN LAS PINZAS GUIA INFERIOR CORRESPONDIENTE, GRADUANDO EN ALTURA Y NIVELANDO LAS HOJAS CORREDERAS AL CIERRE CENTRAL, HACIENDO DESCENDER LA HOJA MEDIANTE LOS TORNILLOS DE REGULACION DE RUEDAS, CON UN DESTORNILLADOR.

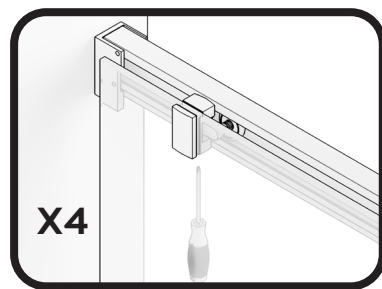
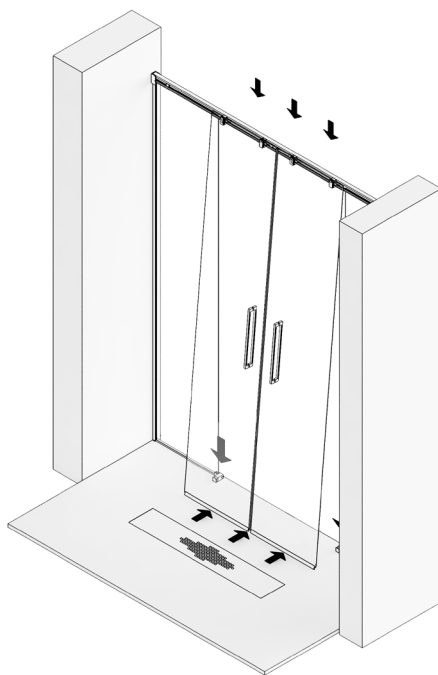

12

COLOCAMOS LAS GOMAS ALA DE CRUCE, UNAS EN LOS FIJOS Y OTRAS EN LAS HOJAS CORREDERAS. COLOCAR LAS ASAS TIRADOR.

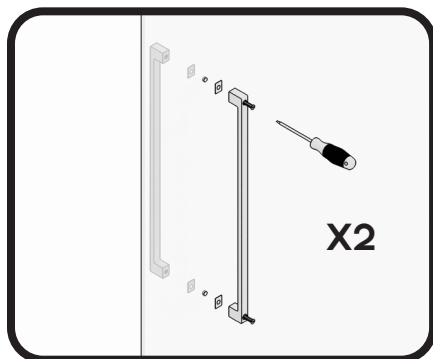
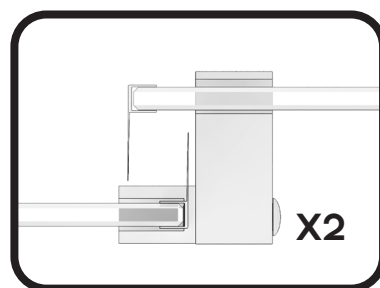

13

COLOCAR LAS GOMAS CIERRE IMAN FRONTAL EN LOS CANTOS EXTERIORES DE LA HOJAS CORREDERAS.

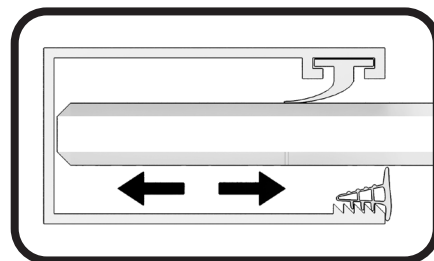
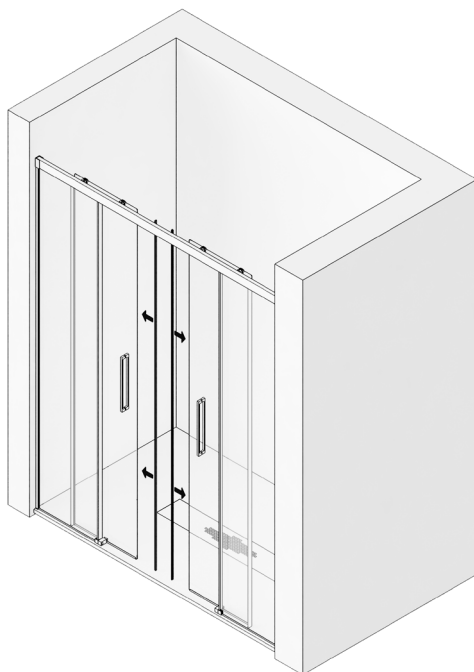

AJUSTAR EL JUEGO DE LOS VIDRIOS FIJOS SEGÚN NECESIDAD. FIJAR EL VIDRIO, ENGOMANDO EL CRISTAL CON EL PERFIL A PARED Y CON LA GUIA SUPERIOR.

14

FIJAR LOS TOPES FRENO EN SU POSICIÓN, MEDIANTE SU TORNILLO PRISIONERO.

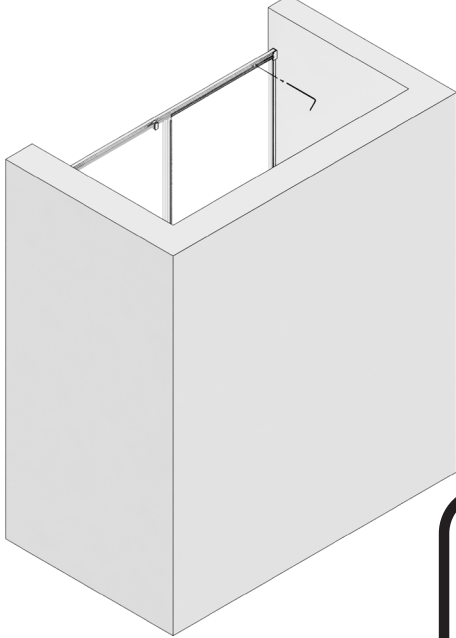
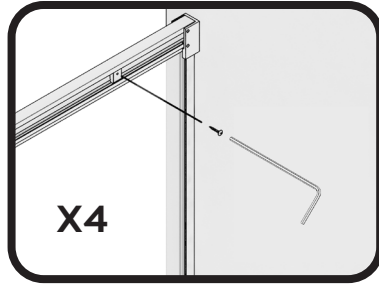

15

MEDIMOS, CORTAMOS, MONTAMOS SUS TAPONES Y PEGAMOS EL PERFIL DE ESTANQUEIDAD, DE PINZA A PINZA INFERIOR, POR DELANTE DE LA HOJA CORREDERA.

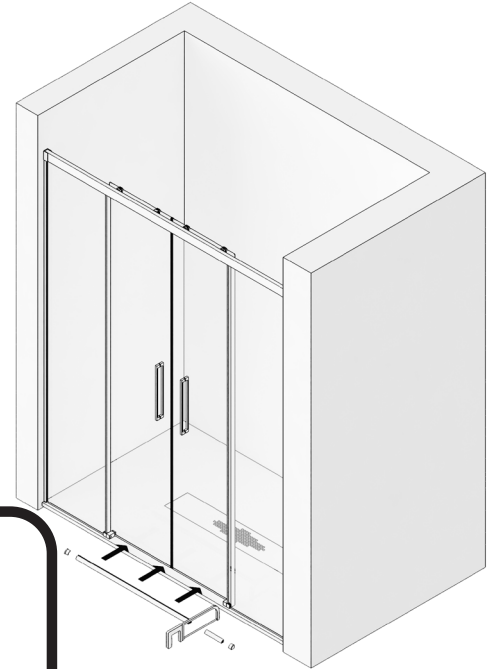

PERFIL DE ESTANQUEIDAD

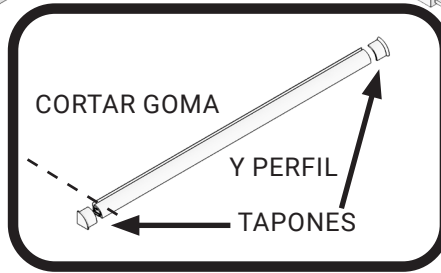





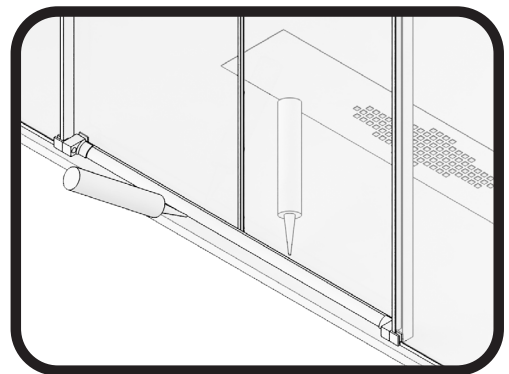



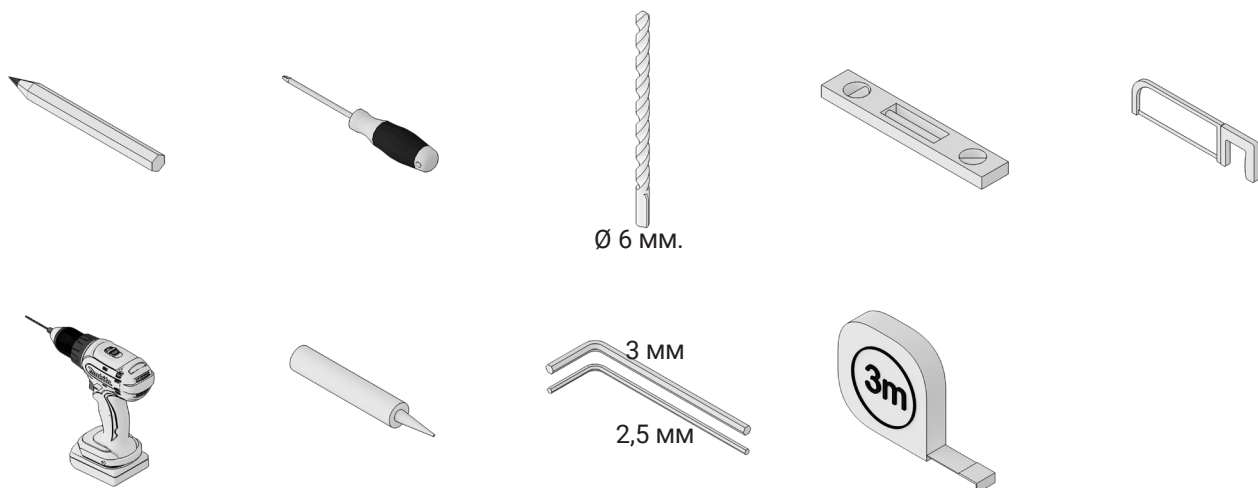

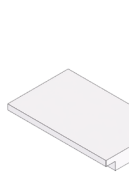
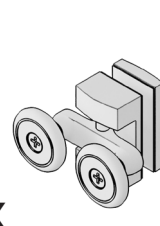
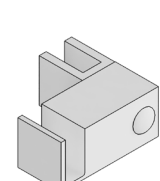
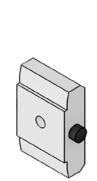
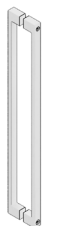

16

SELLAR CON SILICONA EL CONTORNO EXTERIOR DE LA MAMPARA.

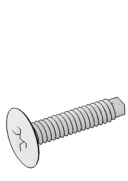

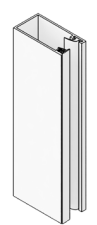
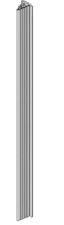
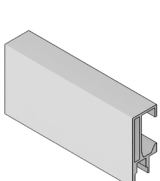
F4

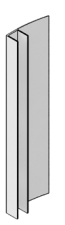
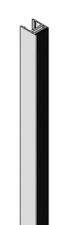
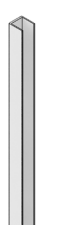

- | | | | | |
|---|---|---|---|---|
| <p>2X</p>  <p>HOJA FIJA</p> | <p>2X</p>  <p>HOJA CORREDERA</p> | <p>2X</p>  <p>VASO O SOPORTE GUÍA</p> | <p>2X</p>  <p>TAPA EMBELLECEDORA VASO SOPORTE GUÍA</p> | <p>4X</p>  <p>RODAMIENTO SUP DOBLE TÁMRFN</p> |
| <p>2X</p>  <p>PINZA GUÍA INFERIOR</p> | <p>4X</p>  <p>TOPE FRENO</p> | <p>2X</p>  <p>ASA TIRADOR</p> | <p>10X</p>  <p>TACOS Nº 6</p> | <p>10X</p>  <p>TORNILLO 4,2 X 32</p> |
| <p>2X</p>  <p>TERMINAL PERFIL DE ESTANQUEIDAD</p> | <p>2X</p>  <p>PERFIL "U" FIJO A PARED</p> | <p>3X</p>  <p>GOMA CUÑA FIJACION VIDRIO</p> | <p>1X</p>  <p>PERFIL GUÍA SUPEROR</p> | <p>1X</p>  <p>PERFIL DE ESTANQUEIDAD</p> |
| <p>4X</p>  <p>GOMAS DE ALA CRUCE FIJO/CORREDERA</p> | <p>2X</p>  <p>CIERRE IMÁN HOJA</p> | <p>1X</p>  <p>GOMA ESTANQUEIDAD INFERIOR FIJO</p> | <p>1X</p>  <p>GOMA INFERIOR VIERTEGUAS PUERTA</p> | |