

# MANUAL DE MONTAJE

## A4



**MAMPARA ANGULAR DE DUCHA**

2 HOJAS CORREDERAS + 2 FIJAS

A4

**1**

PRESENTAMOS PERFILES "U" DE FIJOS, EN PAREDES, NIVELANDOLO, A 3 MM. DEL BORDE DEL PLATO DE DUCHA Y MARCAMOS TALADROS.

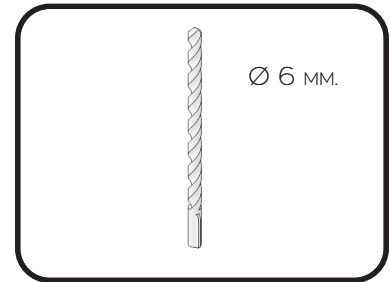
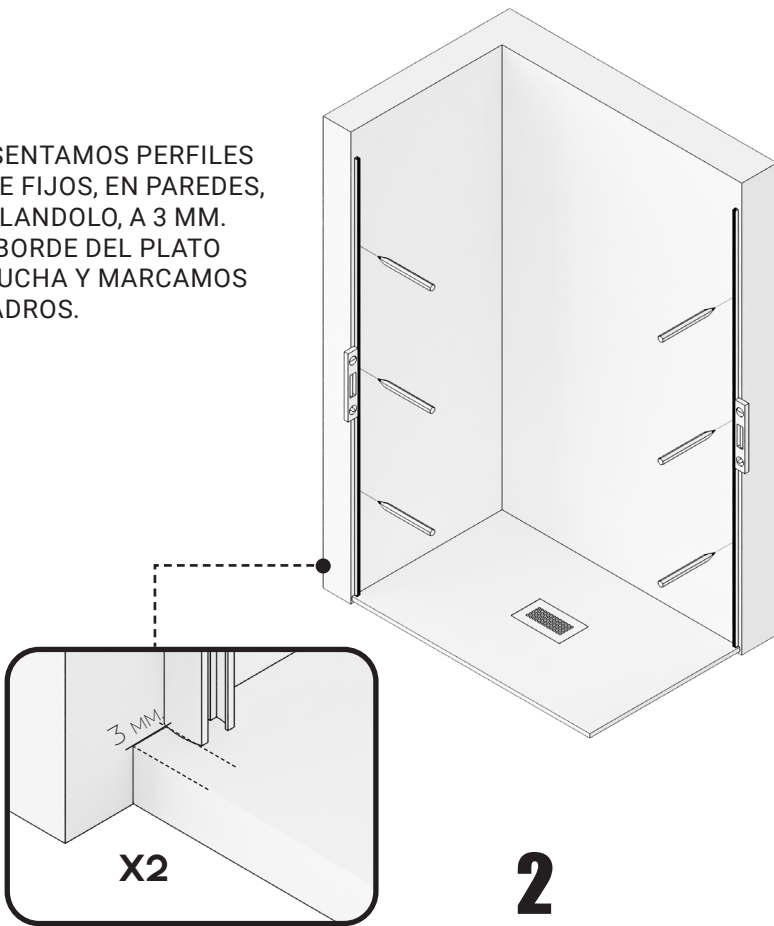

**2**

TALADRAR LA PARED CON BROCA DE 6MM.

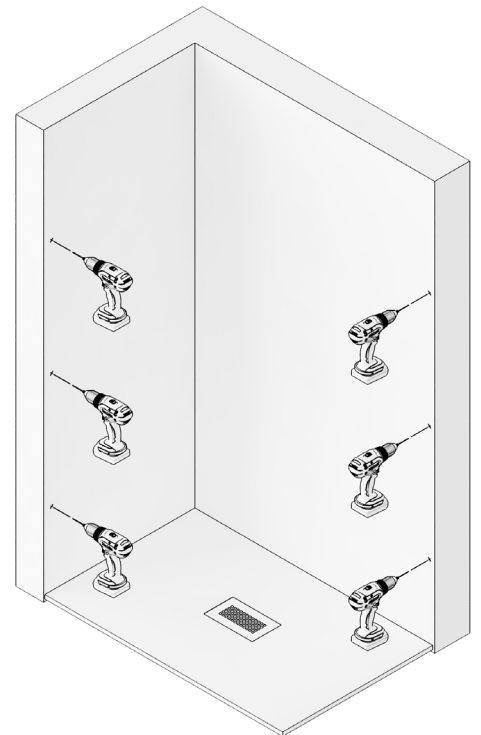

**3**

ATORNILLAR LOS PERFILES "U" A PARED, FIJANDOLOS CON TACOS DEL N° 6 Y LOS 6 TORNILLOS 4.2X32.

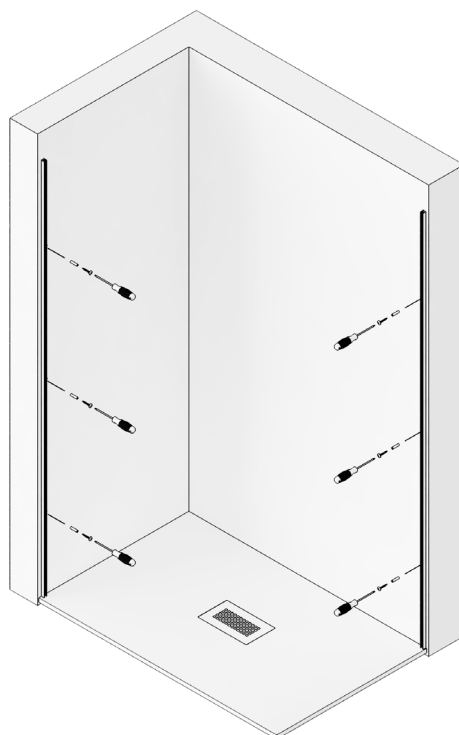

# 4

COLOCAMOS GOMA DE ESTANQUEIDAD INFERIOR EN LAS HOJAS FIJAS E INTRODUCIMOS LOS VIDRIOS EN LAS "U", APOYANDOS SOBRE ESTA.



# 5

COLOCAR LAS PINZAS GUIA INFERIOR EN EL EXTREMO DE LOS VIDRIO FIJO, MONTANDOLAS PREVIAMENTE SEGÚN CORRESPONDA SU POSICIÓN.

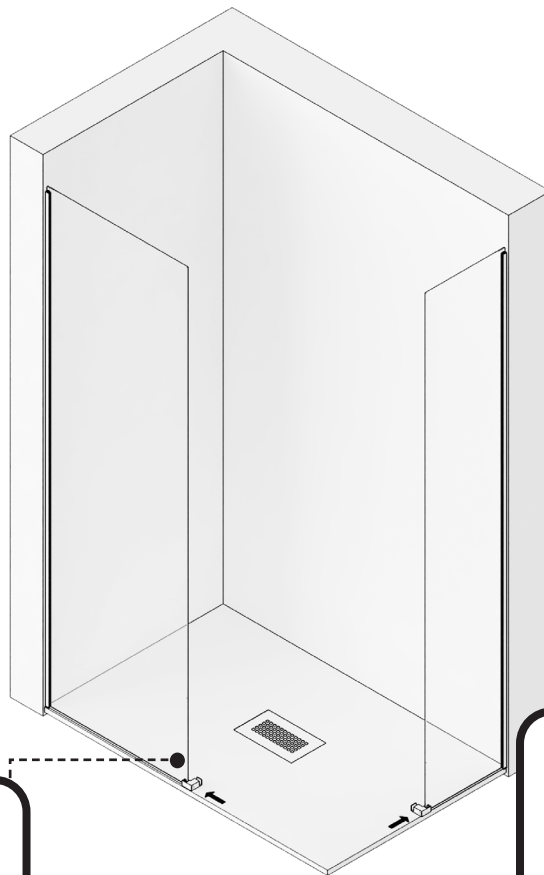

## MONTAJE PINZA GUIA INFERIOR

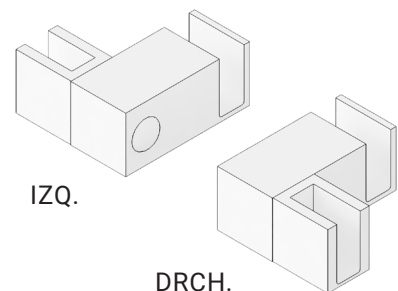
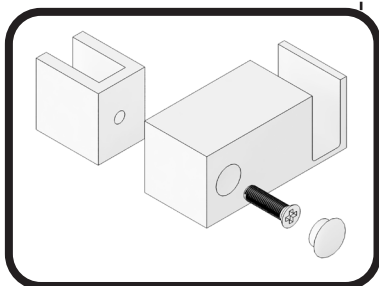

# 6

PRESENTAR GUÍA SUPERIOR CON VASOS Y CODO UNIÓN, FIJÁNDOLO CON SUS TORNILLOS PRISIONEROS, SOBRE LOS VIDRIOS FIJOS. NIVELAR Y MARCAR LOS TALADROS

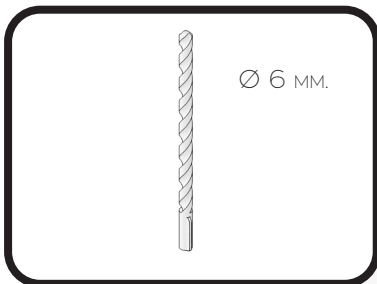
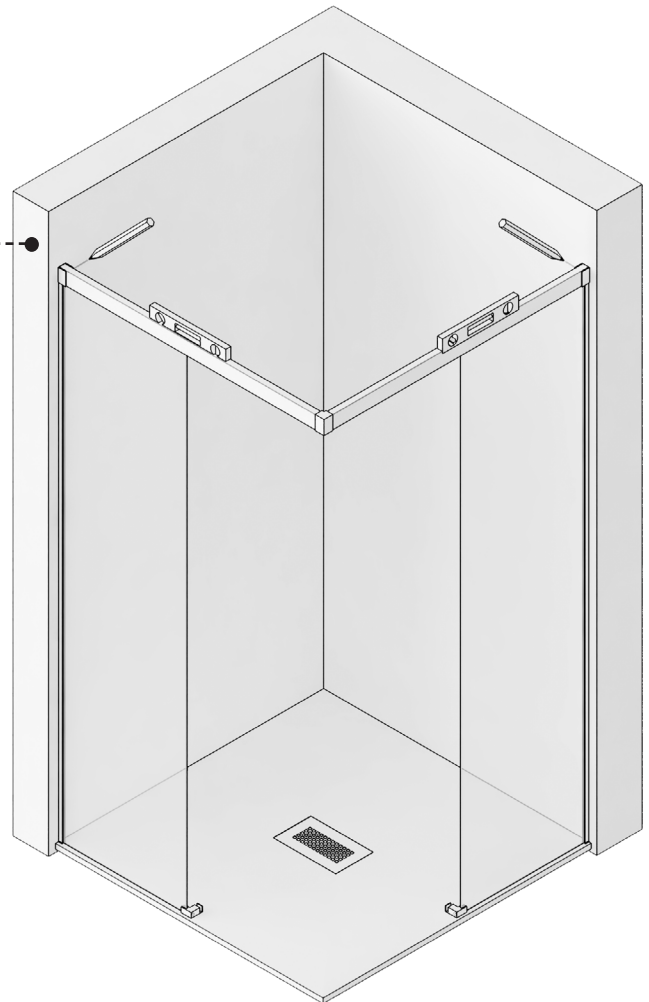
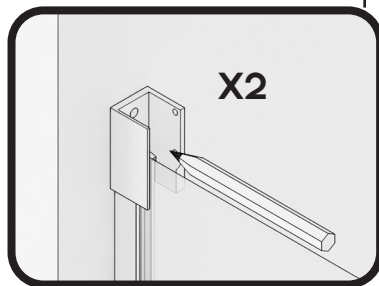

# 7

TALADRAR LA PARED CON BROCA DE 6MM.



RETIRAR CRISTALES FIJOS SI FUESE NECESARIO.

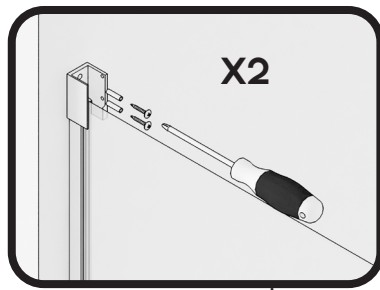

**8**

ATORNILLAR LOS VASOS SOPORTE  
GUÍA SUPERIOR A PARED.

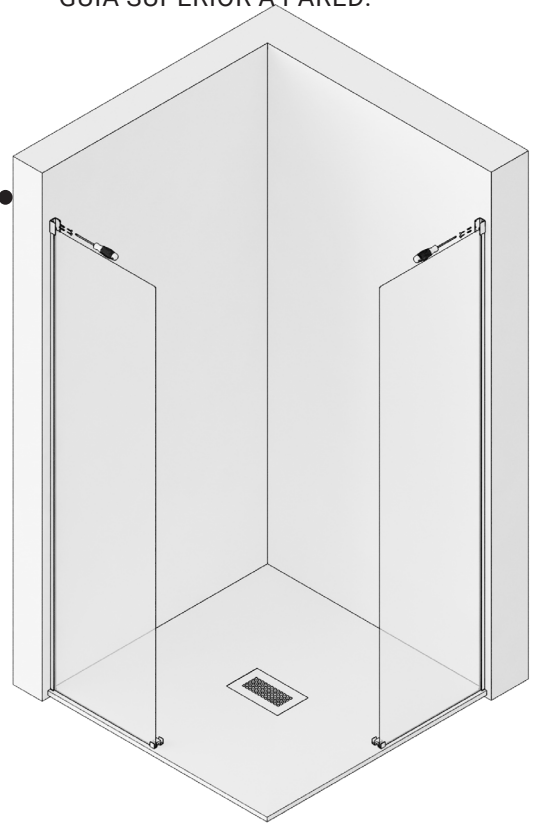

**9**

INTRODUCIR LOS CUATRO RODAMIENTOS  
Y LOS CUATRO TOPE FRENO TRASEROS Y  
CENTRALES EN GUIA SUPERIOR

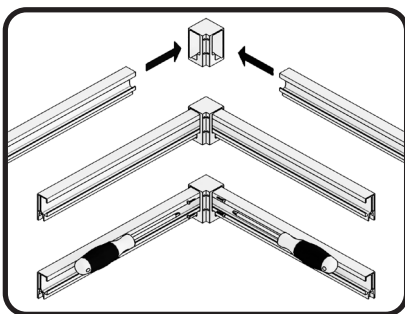
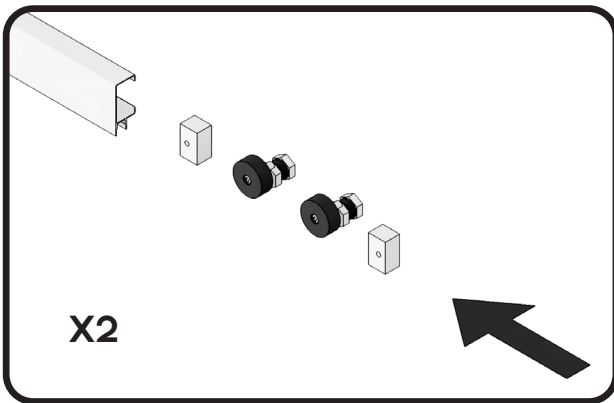

**10**

COLOCAR LA GUIA SUPERIOR UNIDA EN  
LOS VASOS COGIDA A PARED Y FIJAR  
LA COGIDA A LA GUIA MEDIANTE LOS  
TORNILLOS PRISIONEROS CON LLAVE  
HALLEN. ENGOMAR LOS CRISTALES  
FIJOS A PERFILES PARED Y A GUÍA  
SUPERIOR.

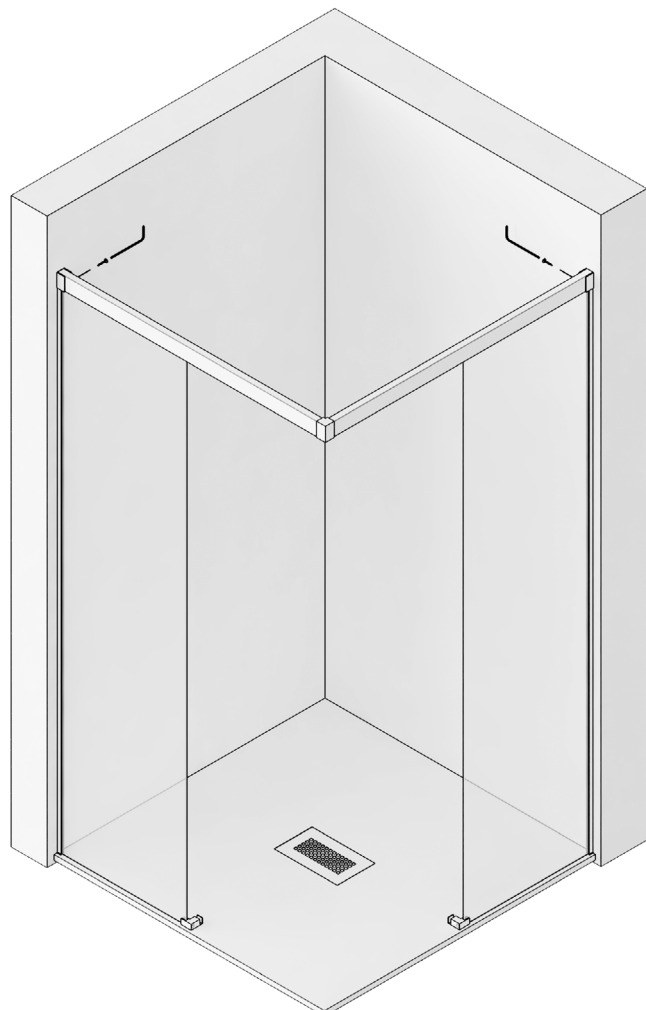

# 11

COLOCAR LA GOMA INFERIOR VIERTEAGUAS EN LAS HOJAS CORREDERAS Y MONTARLAS EN LOS RODAMIENTOS, INTRODUCIENDO LAS MISMAS EN LAS PINZAS GUIA INFERIOR. GRADUAR EN ALTURA Y NIVELAR, HACIENDO GIRAR LOS EJES DE LAS EXCENTRICAS, MEDIANTE LAS TUERCAS DE REGULACION DE RUEDAS, CON DOS LLAVES FIJAS DE 20 MM., FIJANDOLSA FUERTEMENTE EN SU POSICIÓN.

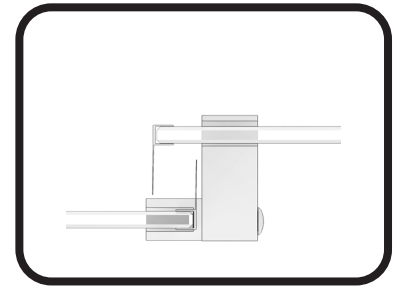
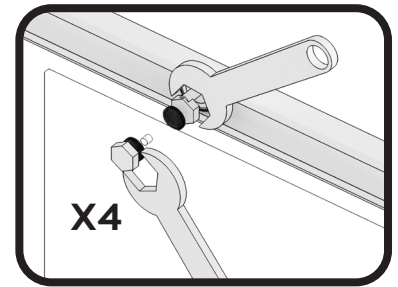
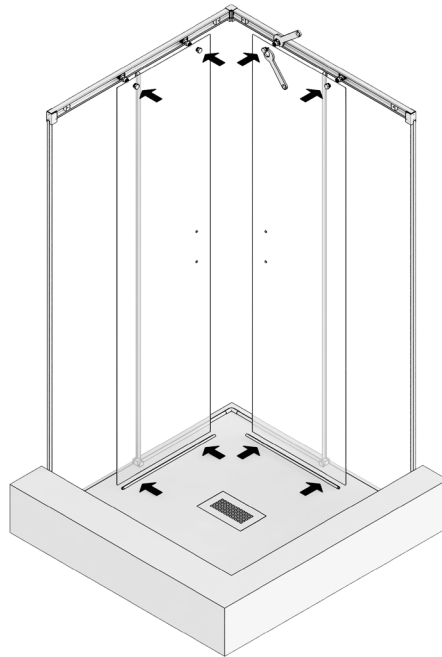

# 12

COLOCAMOS LAS GOMAS ALA DE CRUCE, UNAS EN LOS FIJOS Y OTRAS EN LAS HOJAS CORREDERAS. COLOCAR LAS ASAS TIRADOR.

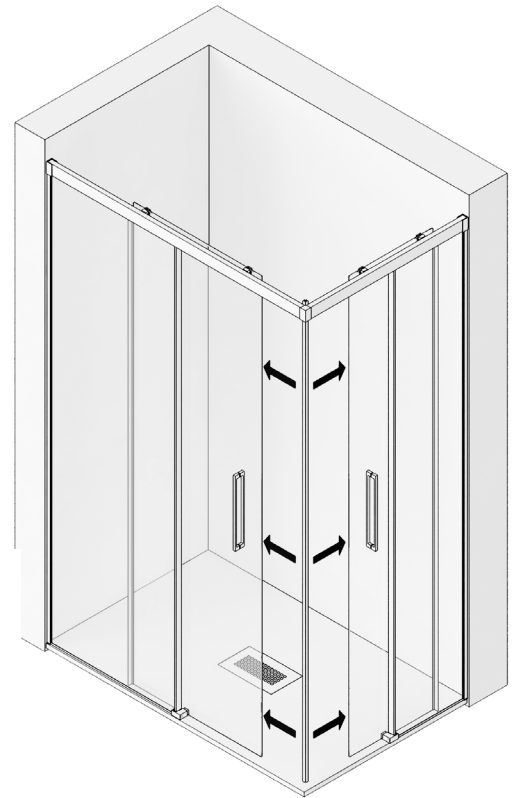
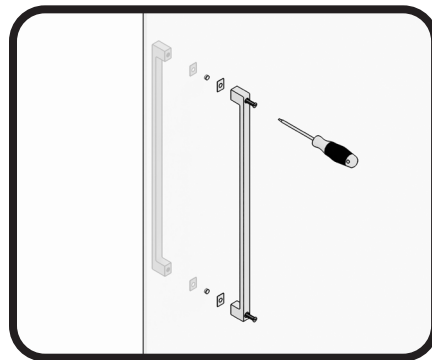

# 13

COLOCAR LOS CIERRE GOMA IMAN ANGULAR EN LOS CANTOS EXTERIORES DE LAS HOJAS CORREDERAS.

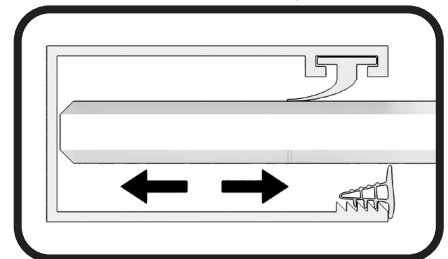

AJUSTAR EL JUEGO DE LOS VIDRIOS FIJOS SEGÚN NECESIDAD. FIJAR EL VIDRIO, ENGOMANDO EL CRISTAL CON EL PERFIL A PARED Y CON LA GUIA SUPERIOR.

# 14

FIJAR LOS TOPE FRENO EN SU POSICIÓN, MEDIANTE SUS TORNILLO PRISIONERO.

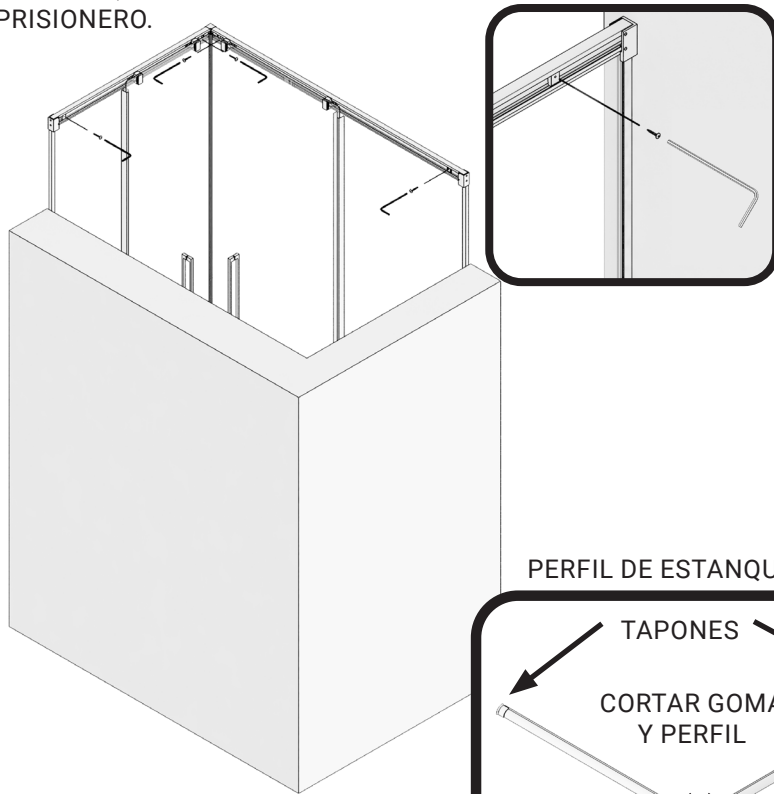

# 15

MEDIMOS, CORTAMOS, MONTAMOS SUS TAPONES Y PEGAMOS EL PERFIL DE ESTANQUEIDAD, DE PINZA INFERIOR AL CODO DEL VERTICE, POR DELANTE DE LAS HOJAS CORREDERAS.







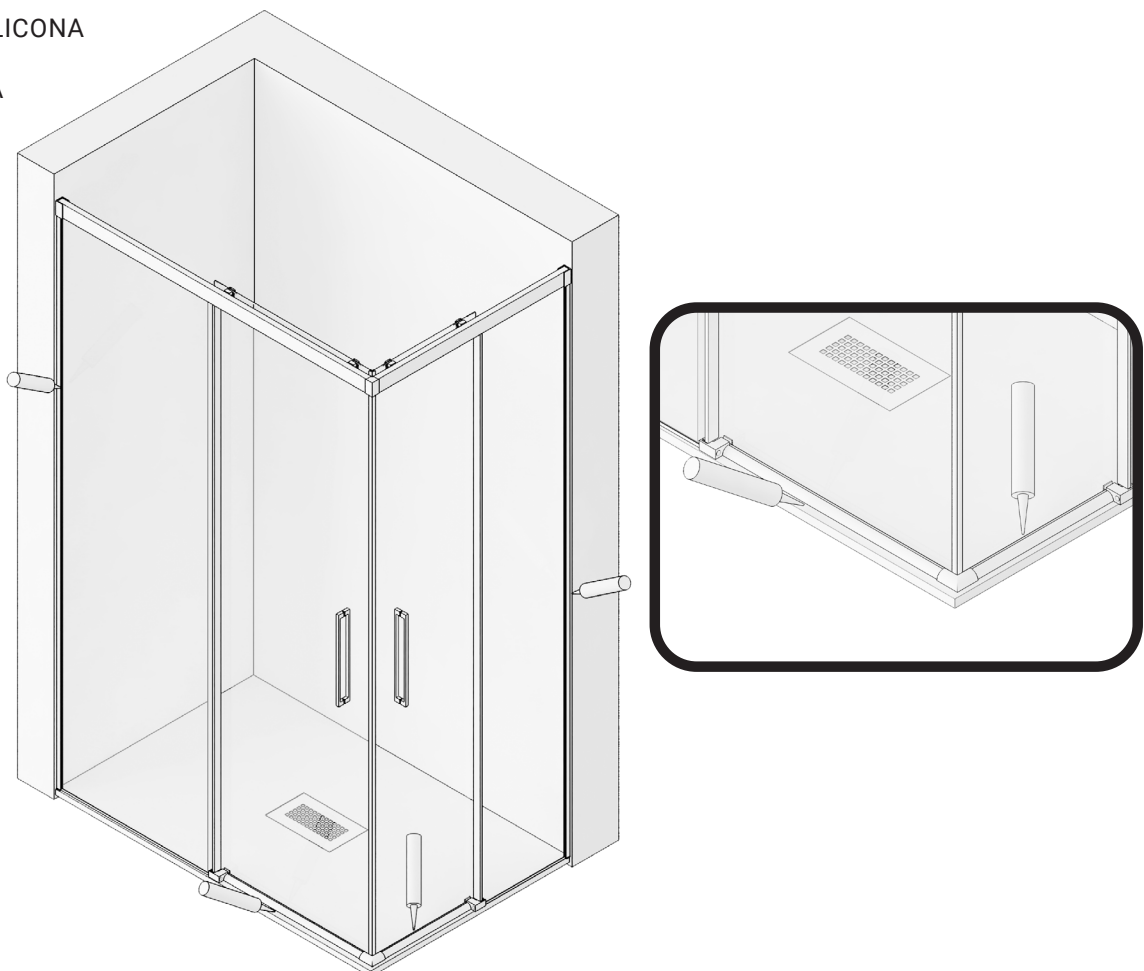



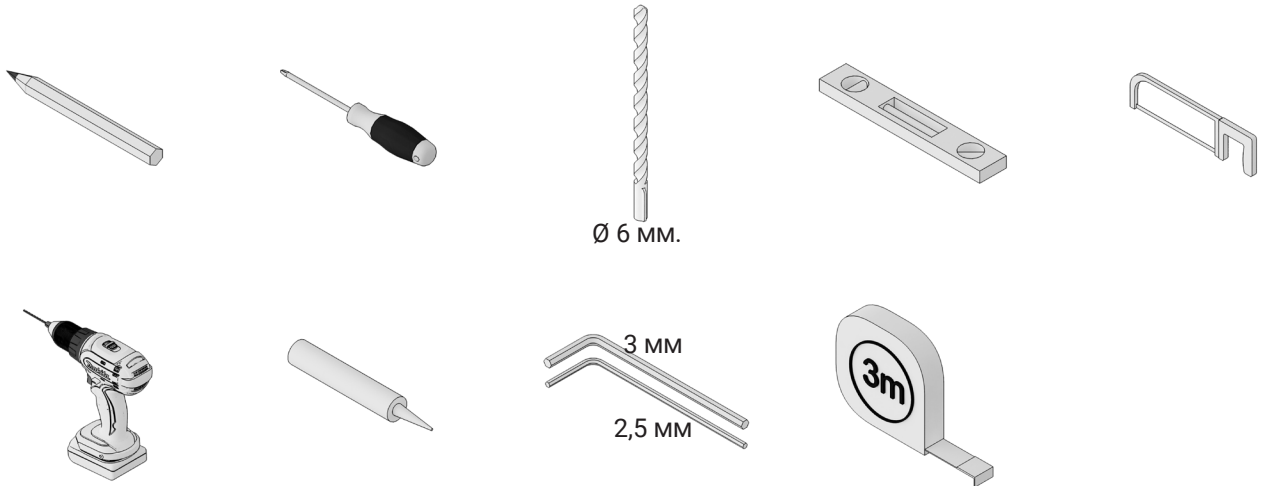

# 16

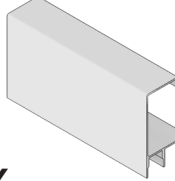
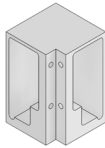
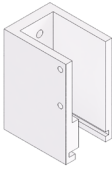
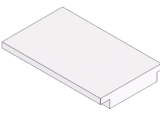
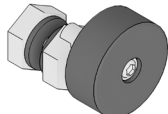
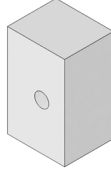
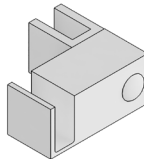
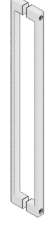
SELLAR CON SILICONA EL CONTORNO EXTERIOR DE LA MAMPARA.

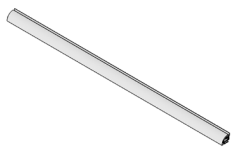

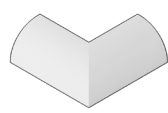
# A4

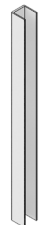
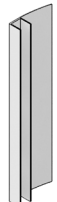
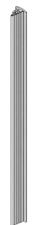

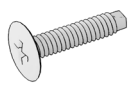
- |   |  |  |  |   |
|---|--|--|--|---|
| <b>2X</b><br><br>HOJA FIJA                                 | <b>2X</b><br><br>HOJA CORREDERA                       | <b>2X</b><br><br>GUÍA SUPERIOR                    | <b>1X</b><br><br>CODO UNIÓN GUÍA              | <b>2X</b><br><br>VASO O SOPORTE GUÍA           |
| <b>2X</b><br><br>TAPA EMBELLECEDORA VASO<br>SOPORTE GUÍA | <b>4X</b><br><br>RODAMIENTO INDUSTRIAL<br>SUPERIOR  | <b>4X</b><br><br>TOPE FRENO                     | <b>2X</b><br><br>GUÍA PINZA INFERIOR         | <b>2X</b><br><br>ASA TIRADOR                 |
| <b>2X</b><br><br>PERFIL "U" FIJO A PARED                 | <b>1X</b><br><br>PERFIL DE ESTANQUEIDAD             | <b>2X</b><br><br>TERMINAL PERFIL<br>VIERTEAGUAS | <b>1X</b><br><br>CODO PERFIL ESTANQUEIDAD    | <b>2X</b><br><br>GOMA CIERRE IMAN<br>ANGULAR |
| <b>1X</b><br><br>GOMA INFERIOR<br>VIERTEAGUAS PUERTA     | <b>1X</b><br><br>GOMA ESTANQUEIDAD<br>INFERIOR FIJO | <b>4X</b><br><br>GOMAS DE ALA CRUCE             | <b>3X</b><br><br>GOMA CUÑA FIJACION<br>VIDRIO | <b>10X</b><br><br>TACOS Nº 6                 |
|   |  |  |  | <b>10X</b><br><br>TORNILLOS 4.2 X 32         |

fabricación  
nacional