

# MANUAL DE MONTAJE

## F2

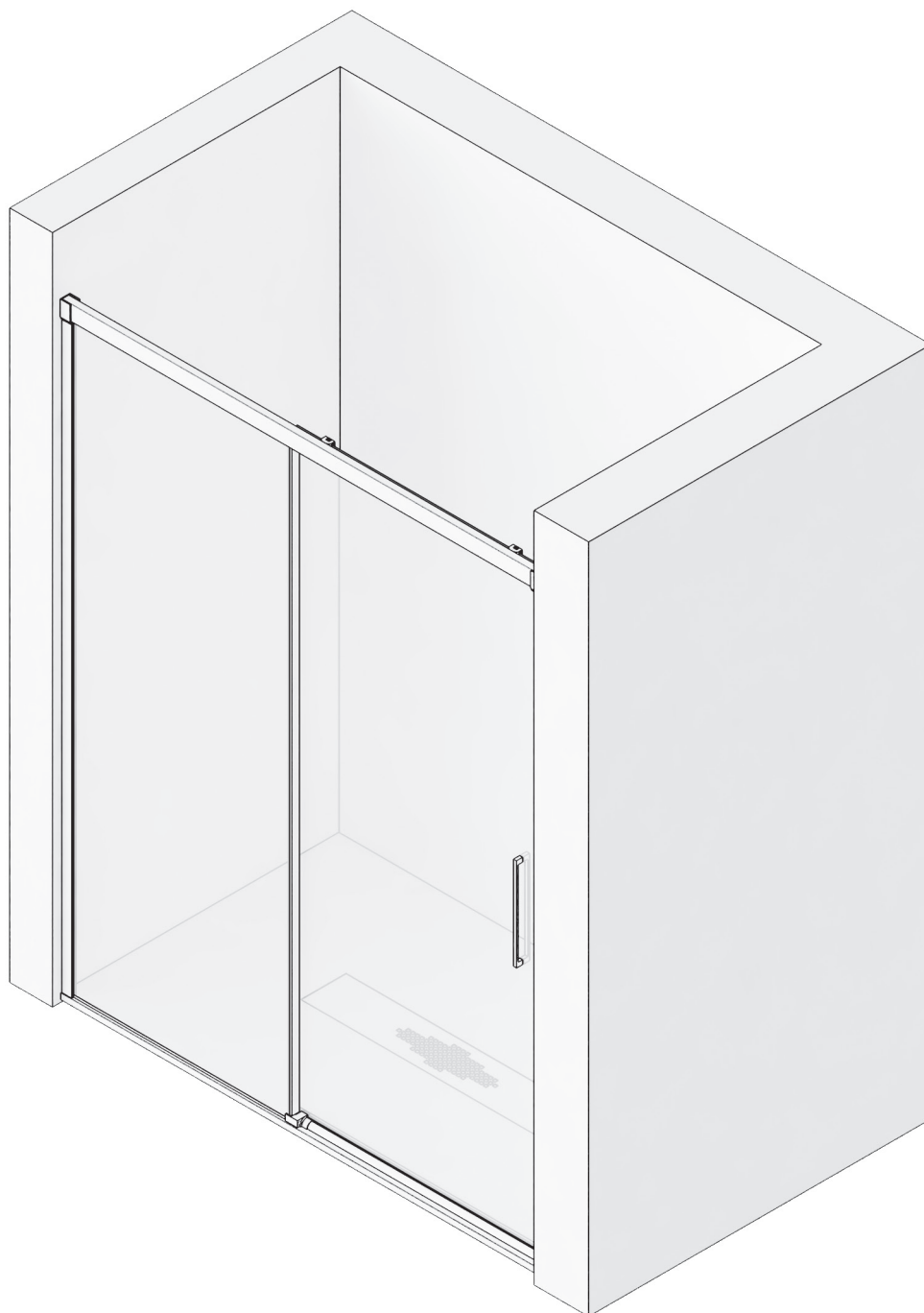

**MAMPARA FRONTAL DE DUCHA**

1 HOJA CORREDERA + 1 FIJA

F2

**1**

PRESENTAMOS PERFIL "U" DE FIJO, EN PARED, SEGÚN CORRESPONDA SU POSICIÓN, NIVELÁNDOLO, A 3 MM. DEL BORDE DEL PLATO DE DUCHA Y MARCAMOS TALADROS.

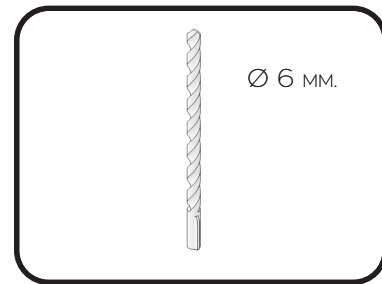
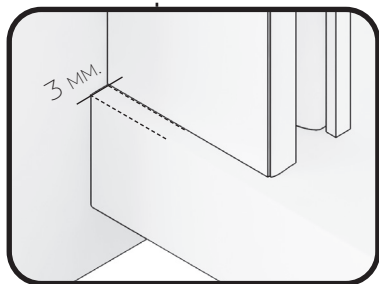
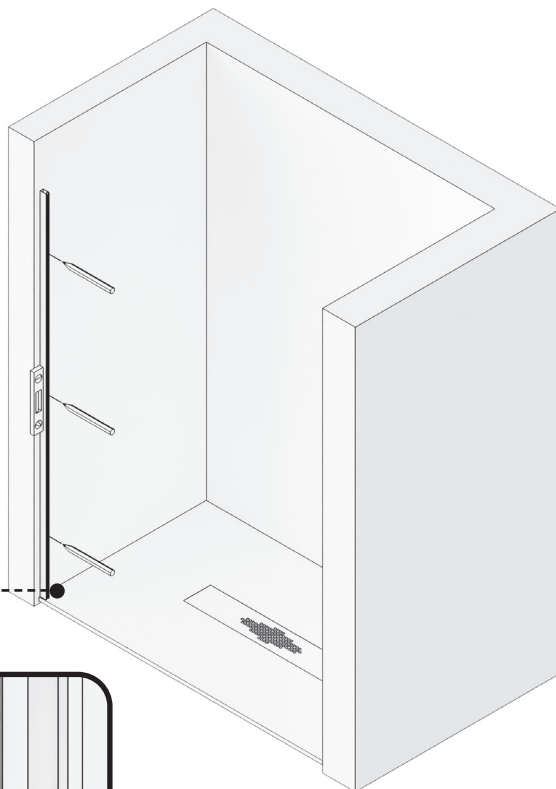

**2**

TALADRAR LA PARED CON BROCA DE 6MM.

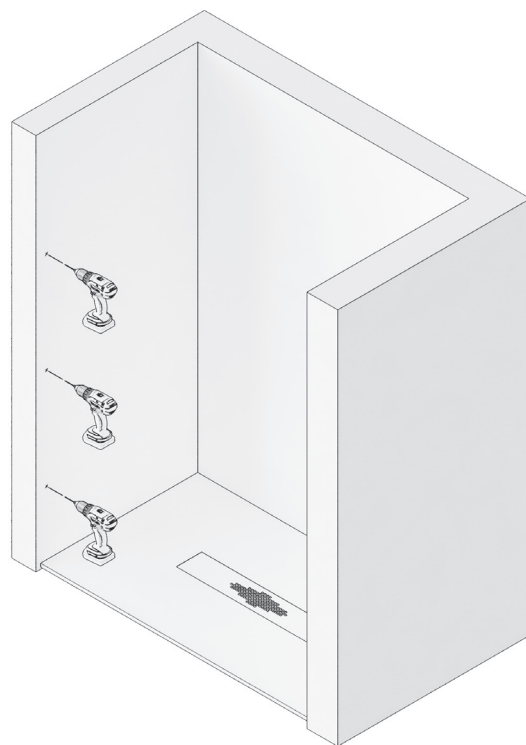

**3**

ATORNILLAR EL PERFIL "U" A PARED, FIJÁNDOLO CON TORNILLOS DEL N° 6 Y LOS 3 TORNILLOS 4.2X32.

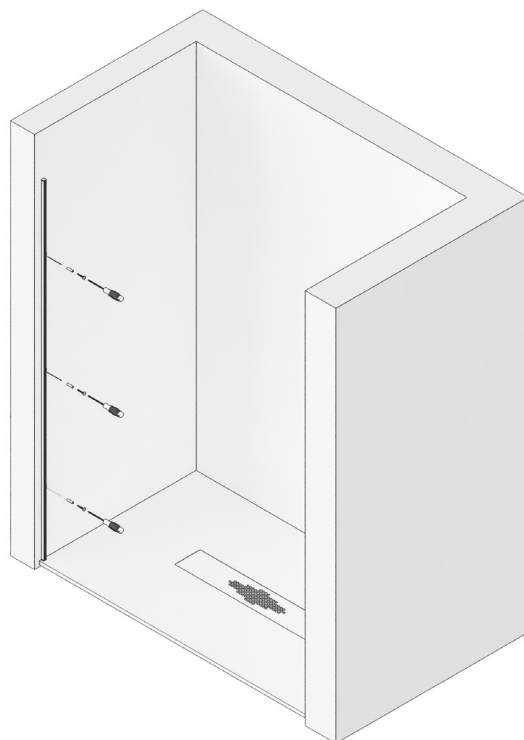

# 4

COLOCAMOS GOMA DE ESTANQUEIDAD INFERIOR EN LA HOJA FIJA E INTRODUCIMOS EL VIDRIO EN LA "U", APOYÁNDOLO SOBRE ESTA.



# 5

COLOCAR LA PINZA GUIA INFERIOR EN EL EXTREMO DEL VIDRIO FIJO, MONTÁNDOLA PREVIAMENTE SEGÚN CORRESPONDA SU POSICIÓN.

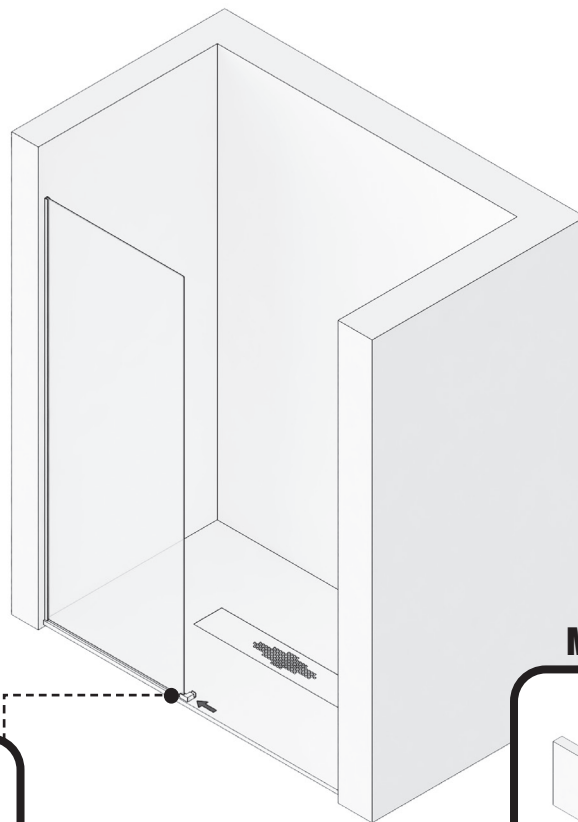

### MONTAJE PINZA GUIA INFERIOR

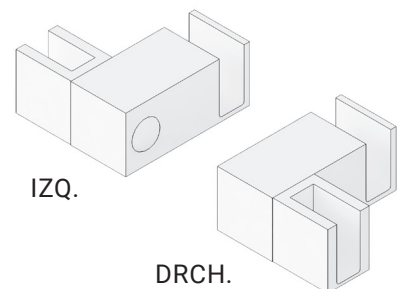
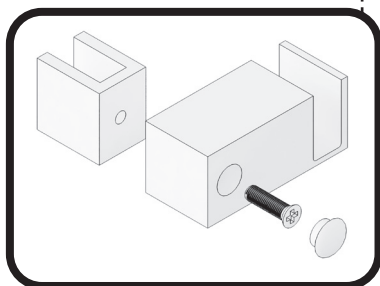

F2

**6**

PRESENTAR GUÍA SUPERIOR  
CON VASOS SOBRE EL VIDRIO  
FIJO, NIVELAR Y MARCAR  
LOS TALADROS.

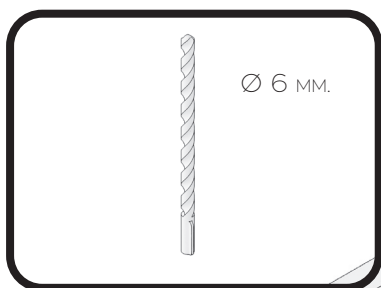
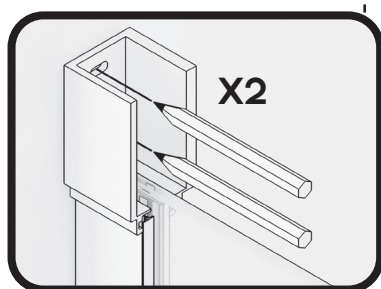

**7**

TALADRAR LA PARED CON  
BROCA DE 6MM.



RETIRAR CRISTALES FIJOS SI FUESE  
NECESARIO.

# 8

ATORNILLAR LOS VASOS SOPORTE  
GUÍA SUPERIOR A PARED.

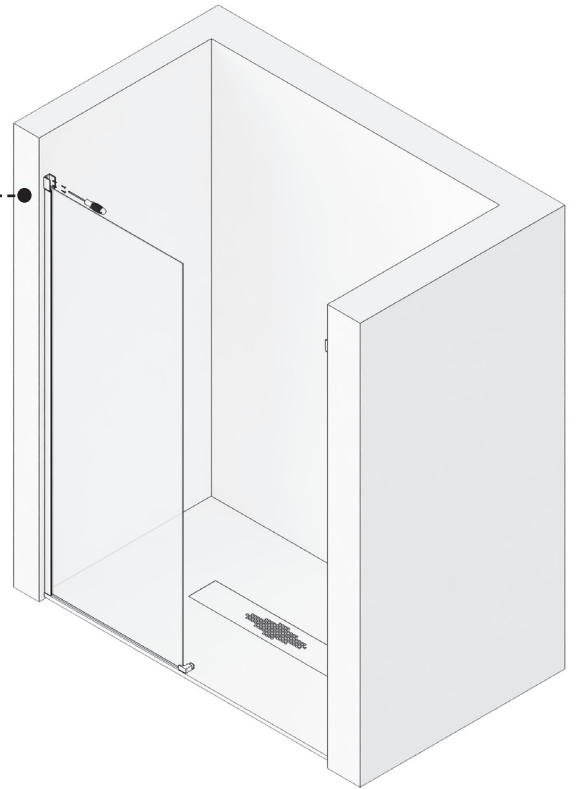
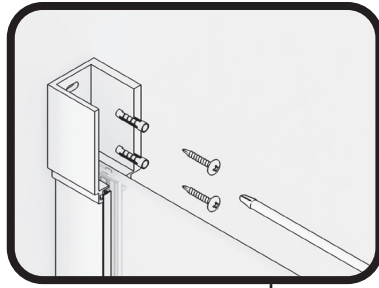

# 9

INTRODUCIR LOS DOS RODAMIENTOS Y EL  
TOPE FRENO TRASERO EN GUÍA SUPERIOR.  
CORTAR EL GUARDARRAIL AL ANCHO  
DEL HUECO OCUPADO POR LA PUERTA  
CORREDERA E INTRODUCIR EN LA GUÍA.

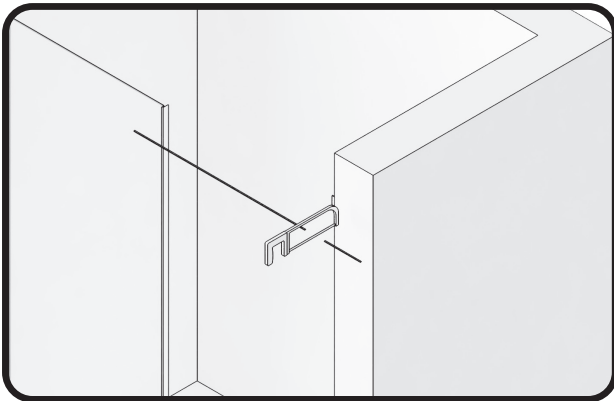
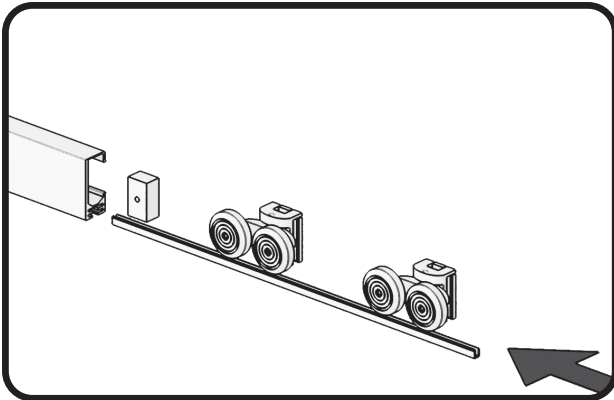

# 10

COLOCAR LA GUÍA SUPERIOR EN LOS VASOS  
COGIDA A PARED Y FIJAR LA COGIDA A LA GUÍA,  
MEDIANTE LOS TORNILLOS PRISIONEROS, CON  
LLAVE ALLEN.  
COLOCAR TAPA EMBELLECEDORA INFERIOR EN  
EL VASO LADO CIERRE.

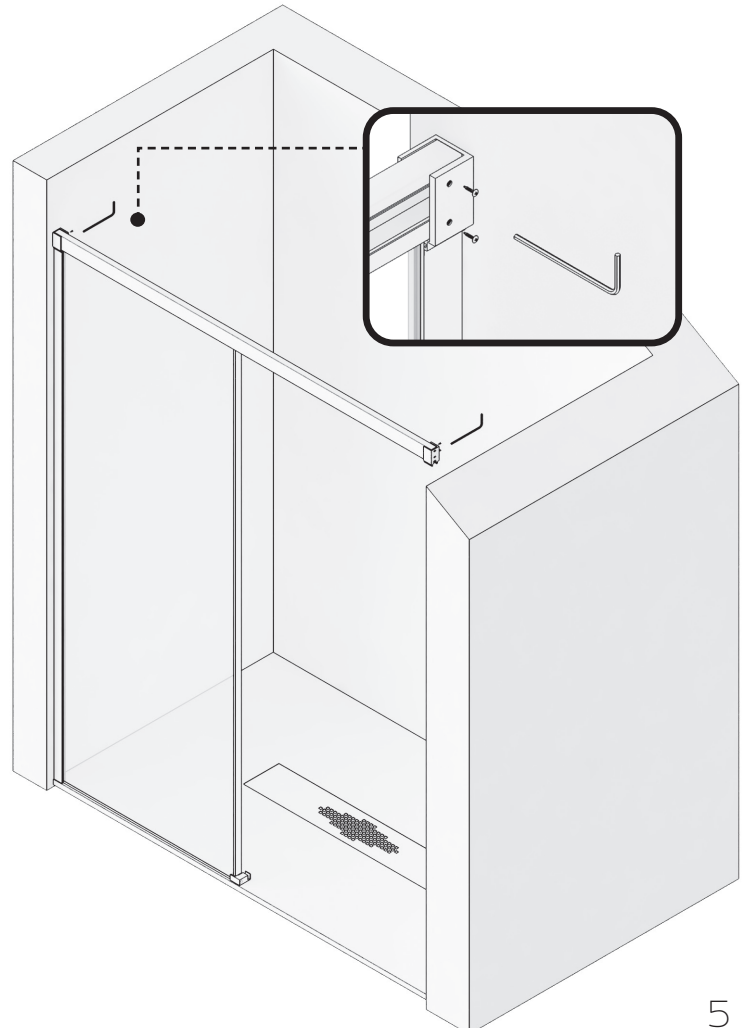
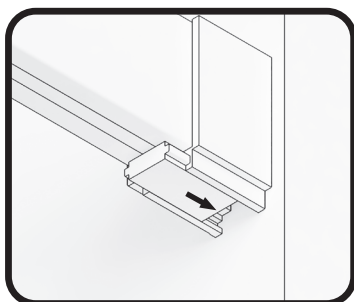

# 11

COLOCAR LA GOMA INFERIOR VIERTEAGUAS EN LA HOJA CORREDERA Y MONTARLA EN LOS RODAMIENTOS, INTRODUCIENDO LA MISMA EN LA PINZA GUIA INFERIOR. GRADUAR EN ALTURA Y NIVELAR, FIJÁNDOLA FUERTEMENTE EN SU POSICIÓN.

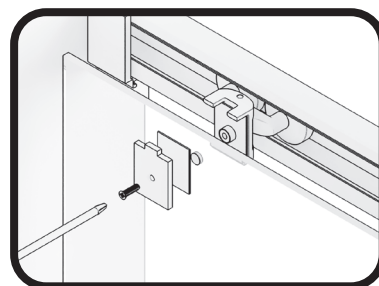
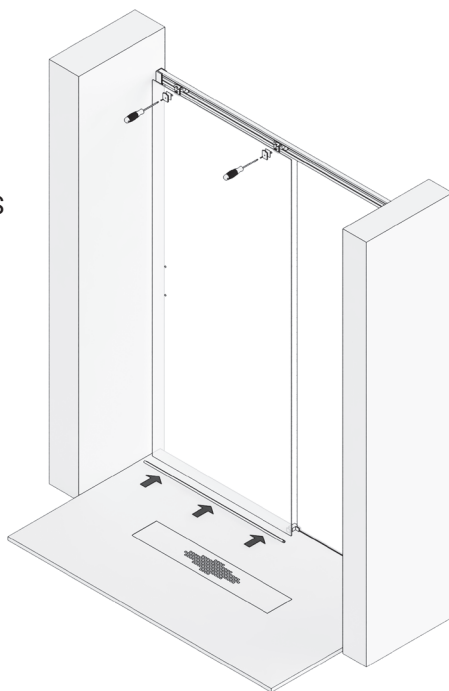

# 12

COLOCAMOS LAS GOMAS ALA DE CRUCE, UNA EN EL FIJO Y OTRA EN LA HOJA CORREDERA. COLOCAR EL ASA TIRADOR.

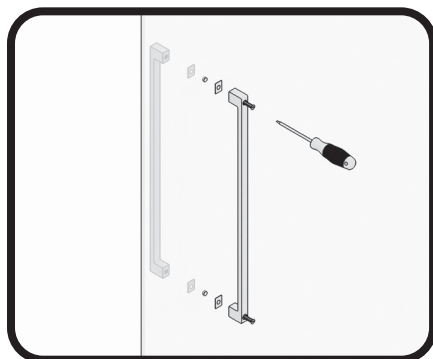
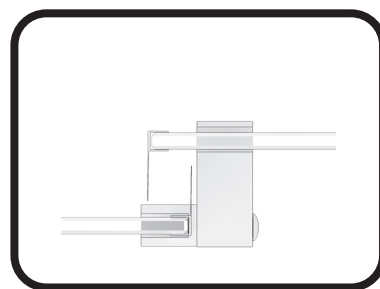

# 13

COLOCAR EL CIERRE GOMA IMAN FRONTAL EN EL CANTO EXTERIOR DE LA HOJA CORREDERA Y PRESENTAR SOBRE ESTE EL PERFIL CIERRE IMAN. APROXIMAR LA HOJA CORREDERA AL CIERRE EN PARED, MARCAMOS SU POSICIÓN, NIVELANDOLO Y ATORNILLÁNDOLO, RETIRANDO EL IMÁN PARA SU COLOCACIÓN.

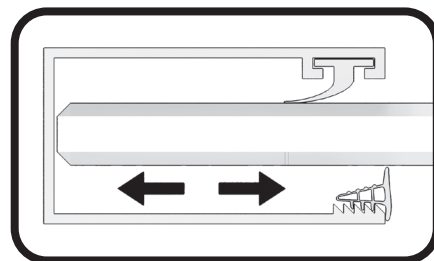

AJUSTAR EL JUEGO DEL VIDRIO FIJO SEGÚN NECESIDAD. FIJAR EL VIDRIO, ENGOMANDO EL CRISTAL CON EL PERFIL A PARED Y CON LA GUIA SUPERIOR.

# 14

FIJAR EL TOPE FRENO EN SU POSICIÓN, MEDIANTE SU TORNILLO PRISIONERO.

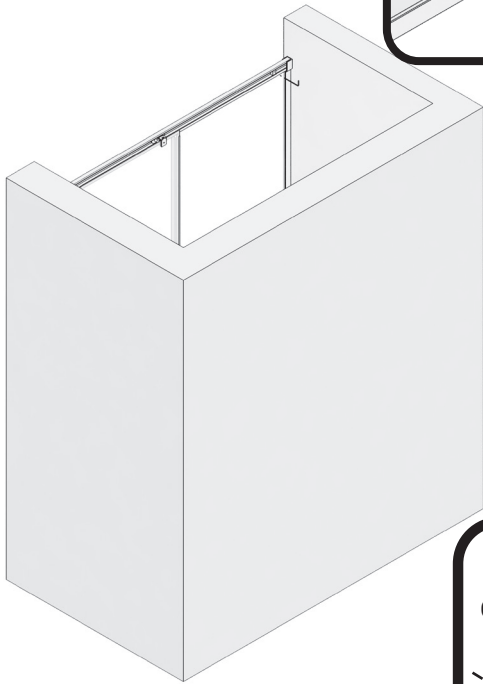
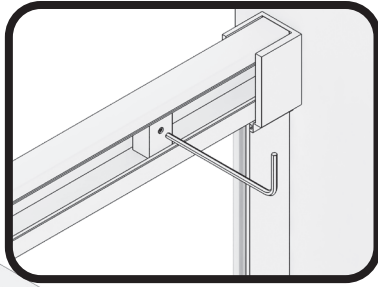

# 15

MEDIMOS, CORTAMOS, MONTAMOS SUS TAPONES Y PEGAMOS EL PERFIL DE ESTANQUEIDAD, DE PINZA INFERIOR A PARED POR DELANTE DE LA HOJA CORREDERA.

PERFIL DE ESTANQUEIDAD

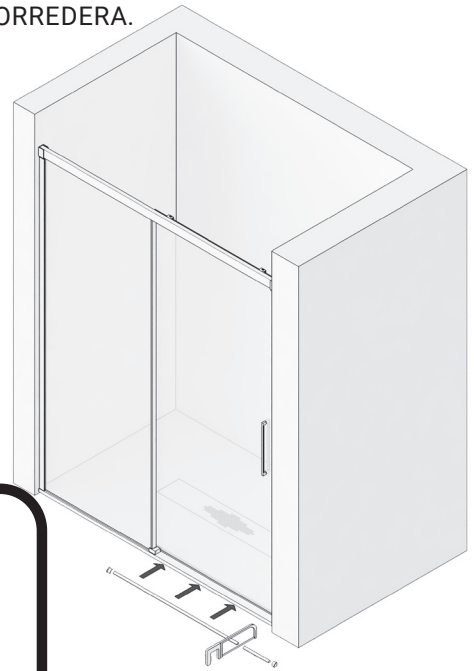
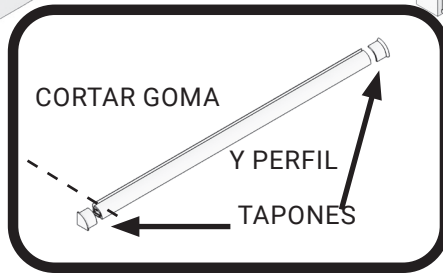

# 16

SELLAR CON SILICONA EL CONTORNO EXTERIOR DE LA MAMPARA.

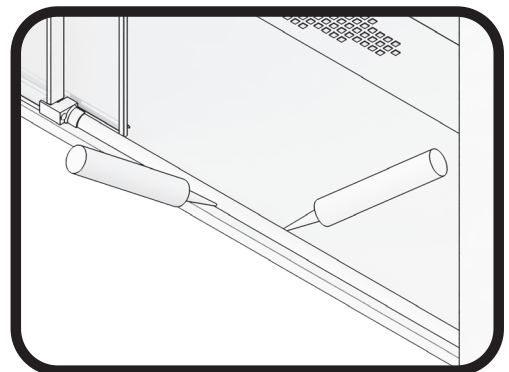

# F2

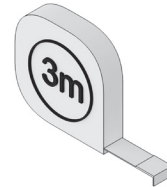
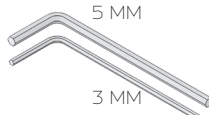
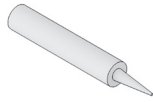
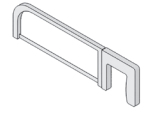
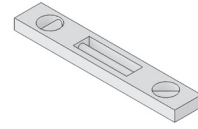
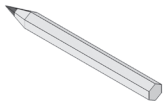

1X

HOJA FIJA



1X

HOJA CORREDERA

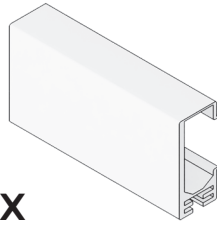

1X

PERFIL GUÍA SUPERIOR



1X

VARILLA GUÍA SUPERIOR

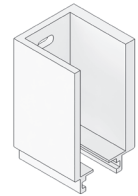

2X

VASO SOPORTE GUÍA

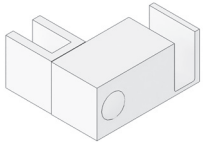

1X

PINZA GUÍA INFERIOR

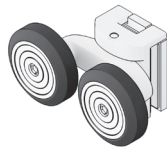

2X

RODAMIENTO INDUSTRIAL SUPERIOR

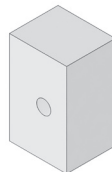

1X

TOPE FRENO



1X

ASA TIRADOR



1X

PERFIL "U" FIJO A PARED



1X

CIERRE IMÁN A PRED



1X

TAPA PERFIL CIERRE IMÁN



1X

PERFIL DE ESTANQUEIDAD



2X

TAPONES PERFIL ESTANQUEIDAD



1X

GOMA CIERRE IMAN FRONTAL



1X

GOMA INFERIOR VIERTEAGUAS PUERTA



1X

GOMA ESTANQUEIDAD FIJO



2X

GOMA ALA CRUCE



10X

TACOS N°6

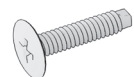

10X

TORNILLOS 4.2 X 32

fabricación nacional