

MANUAL DE MONTAJE

F4



MAMPARA FRONTAL DE DUCHA

2 HOJAS CORREDERAS + 2 FIJAS

F4

1

PRESENTAMOS PERFILES "U" DE FIJO, EN PAREDES, NIVELANDOLOS A 3 MM. DEL BORDE DEL PLATO DE DUCHA Y MARCAMOS TALADROS.

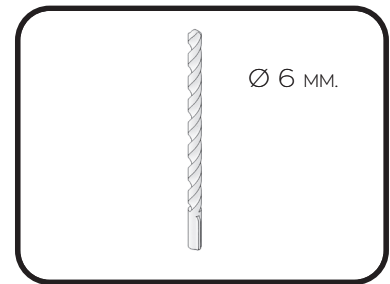
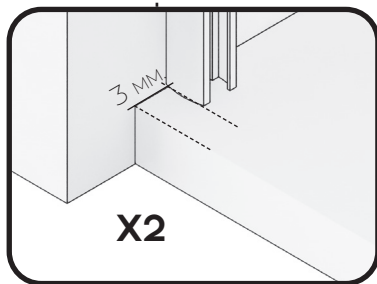

2

TALADRAR LAS PAREDES CON BROCA DE 6MM.

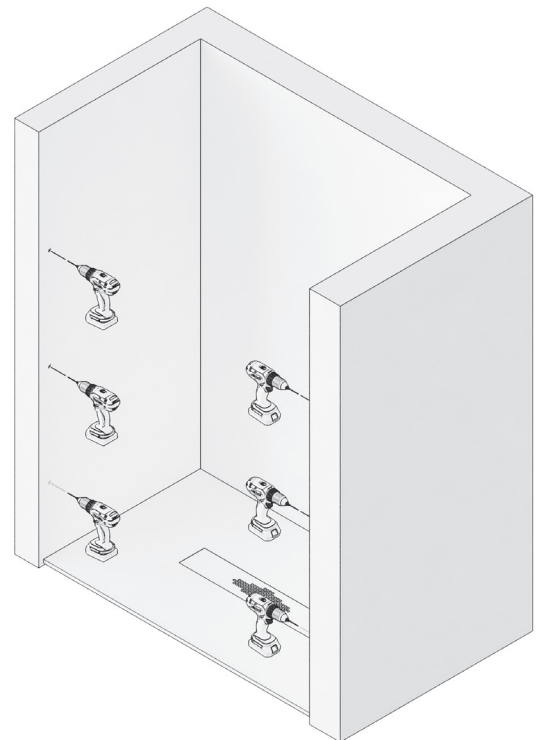

3

ATORNILLAR LOS PERFILES "U" A PAREDES, FIJANDOLOS CON TACOS DEL Nº 6 Y LOS 6 TORNILLOS 4.2X32

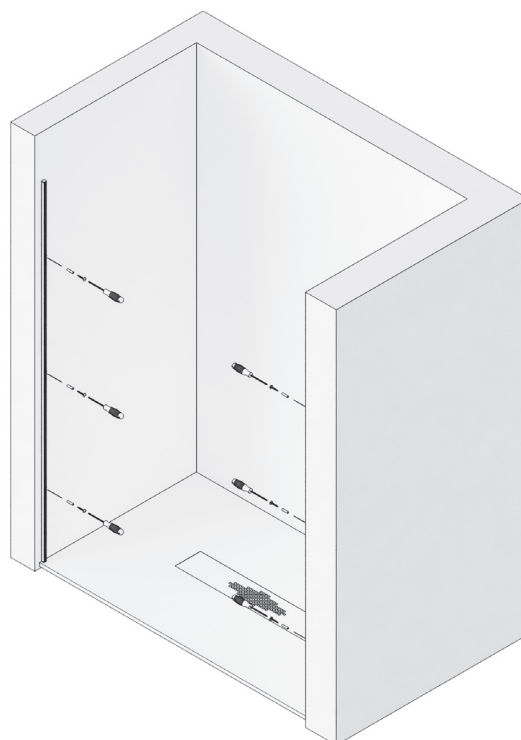

4

COLOCAMOS LAS GOMAS DE ESTANQUEIDAD INFERIORES EN LAS HOJAS FIJAS E INTRODUCIMOS LOS VIDRIOS EN LAS "U", SEGÚN CORRESPONDA SU POSICIÓN, APOYÁNDOLOS SOBRE ESTAS.



5

COLOCAR LAS PINZAS GUIA INFERIORES EN LOS EXTREMO DE LOS VIDRIOS FIJOS, MONTANDOLAS PREVIAMENTE SEGÚN CORRESPONDA SU POSICIÓN.

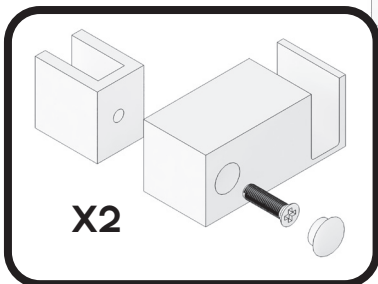
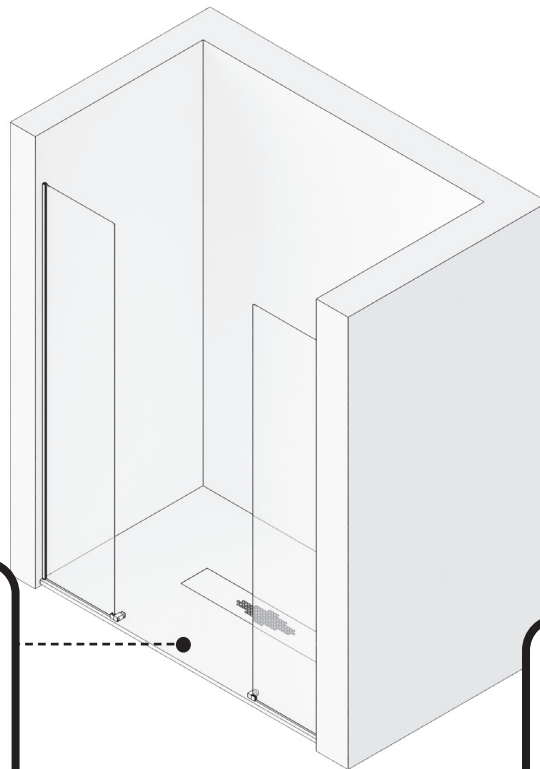

MONTAJE PINZA GUIA INFERIOR

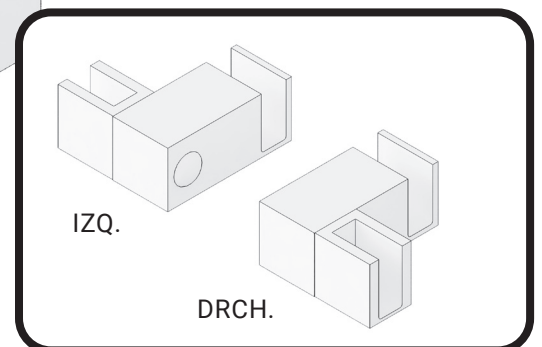

F4

6

PRESENTAR GUÍA SUPERIOR
CON VASOS SOBRE LOS
VIDRIOS FIJOS, NIVELAR Y
MARCAR LOS TALADROS.

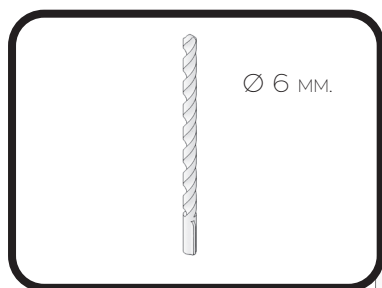
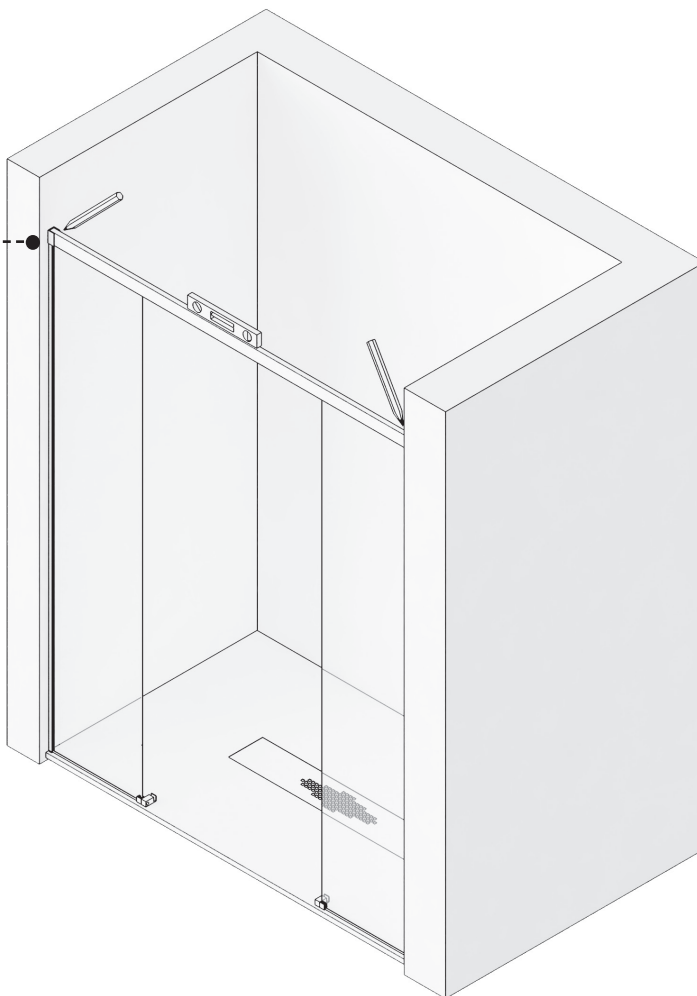
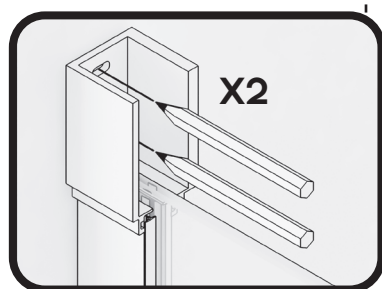

7

TALADRAR LA PARED CON
BROCA DE 6MM.

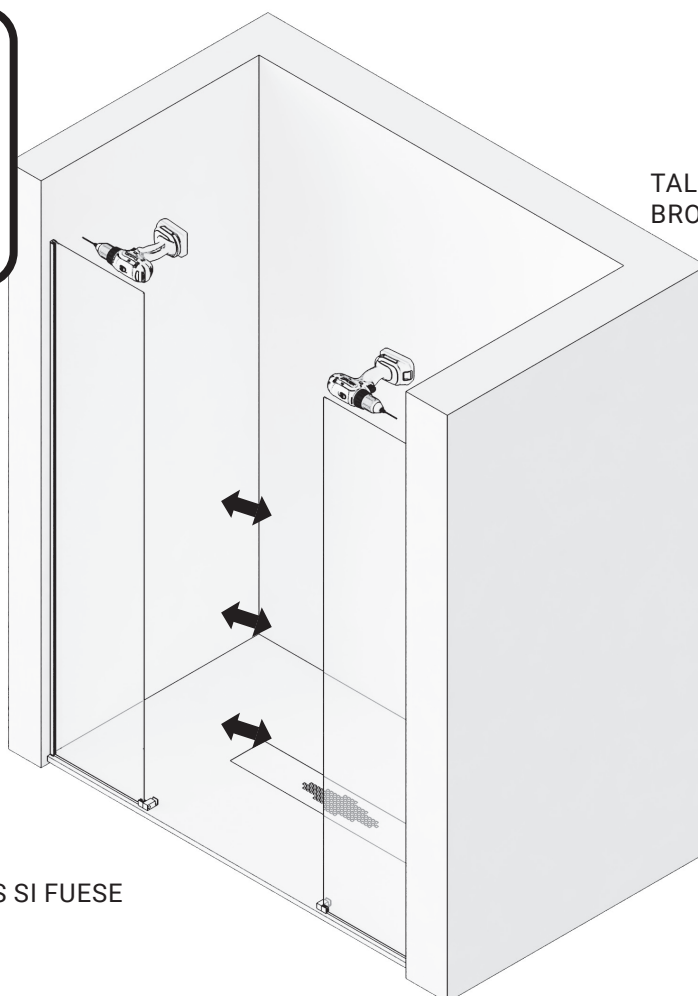

RETIRAR CRISTALES FIJOS SI FUESE
NECESARIO.

9

INTRODUCIR LOS CUATRO RODAMIENTOS Y TOPES DE FRENO EN GUIA SUPERIOR, ASÍ COMO EL GUARDARRAIL.
CORTAR EL GUARDARRAIL AL ANCHO DEL HUECO OCUPADO POR LA PUERTA CORREDERA E INTRODUCIR EN LA GUÍA.

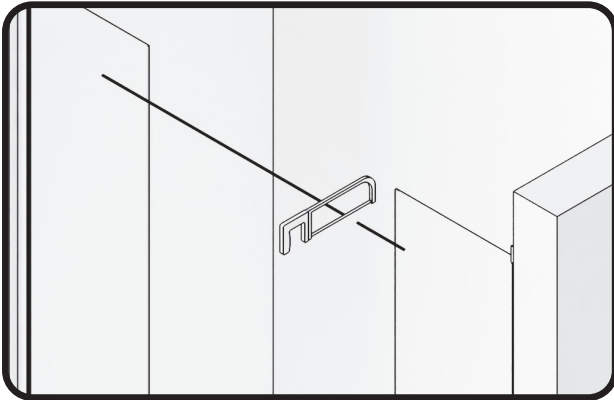
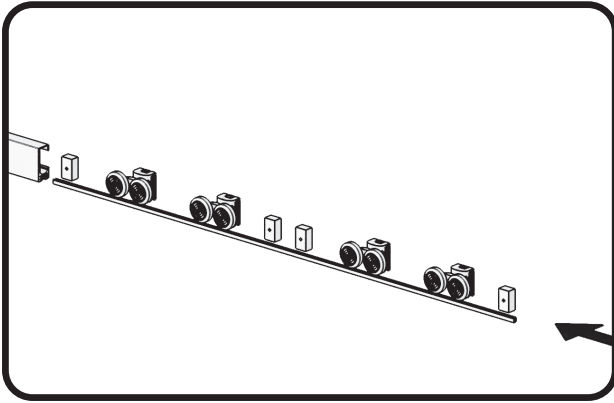

10

COLOCAR LA GUIA SUPERIOR EN LOS VASOS COGIDA A PARED Y FIJAR LA COGIDA A LA GUIA, MEDIANTE LOS TORNILLOS PRISIONEROS, CON LLAVE ALLEN.

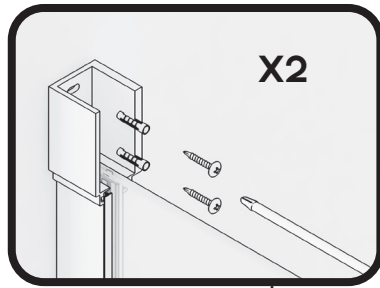

8

ATORNILLAR LOS VASOS SOPORTE GUÍA SUPERIOR A PARED.

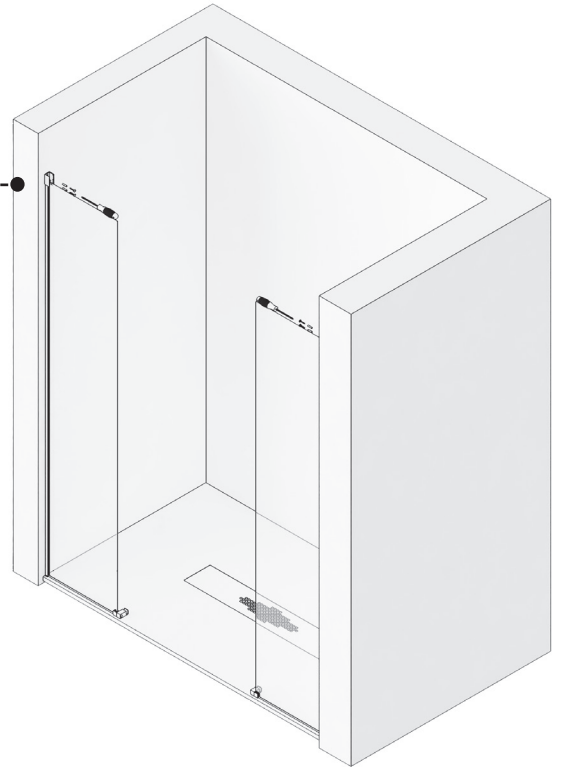

X2

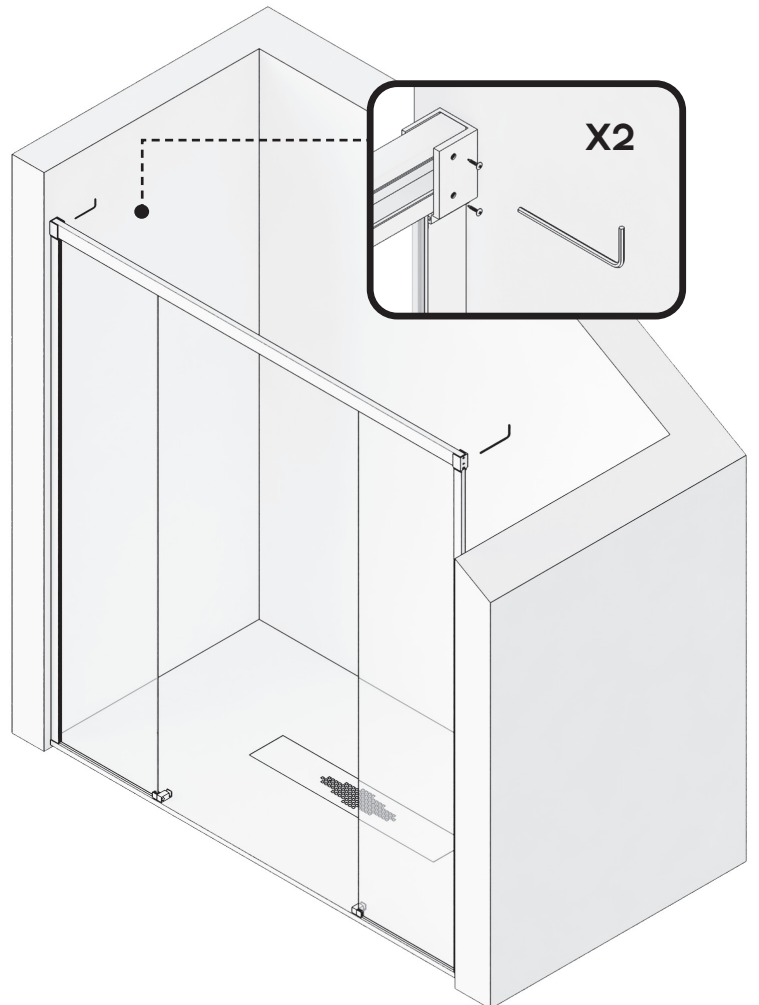

11

COLOCAR LAS GOMAS INFERIORES VIERTEAGUAS EN LAS HOJAS CORREDERAS Y MONTARLAS EN LOS RODAMIENTOS, INTRODUCIENDO LAS MISMAS EN LAS PINZAS GUIA INFERIORES. GRADUAR EN ALTURA Y NIVELAR, FIJÁNDOLAS FUERTEMENTE EN SU POSICIÓN.

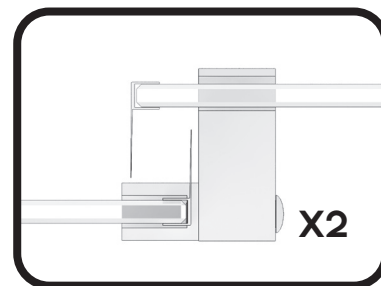
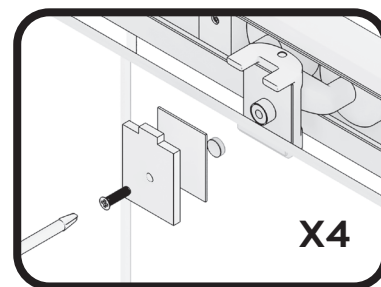
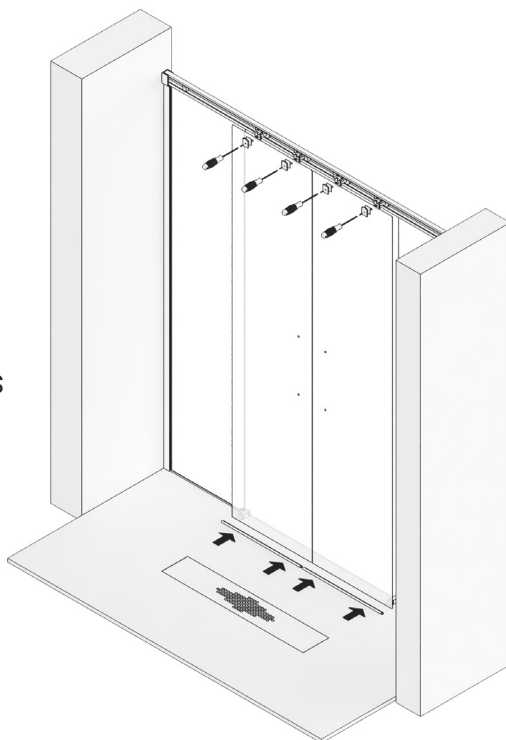

12

COLOCAMOS LAS GOMAS ALA DE CRUCE, UNAS EN LOS FIJOS Y OTRAS EN LAS HOJAS CORREDERAS. COLOCAR LAS ASAS TIRADOR.

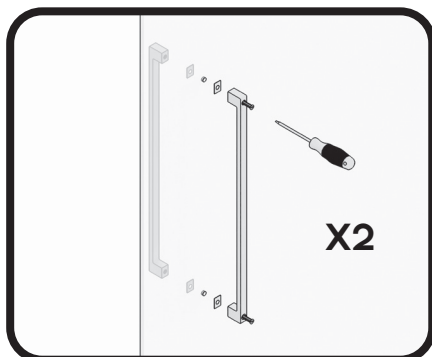

13

COLOCAR LAS GOMAS CIERRE IMAN FRONTAL EN LOS CANTOS EXTERIORES DE LA HOJAS CORREDERAS.



14

FIJAR LOS TOPES FRENO EN SU POSICIÓN, MEDIANTE SU TORNILLO PRISIONERO.

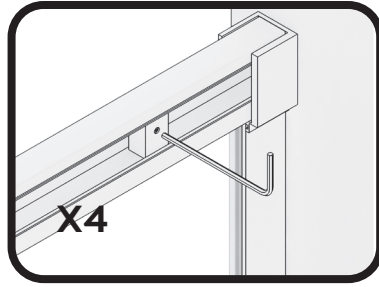

15

MEDIMOS, CORTAMOS, MONTAMOS SUS TAPONES Y PEGAMOS EL PERFIL DE ESTANQUEIDAD, DE PINZA A PINZA INFERIOR, POR DELANTE DE LA HOJA CORREDERA.

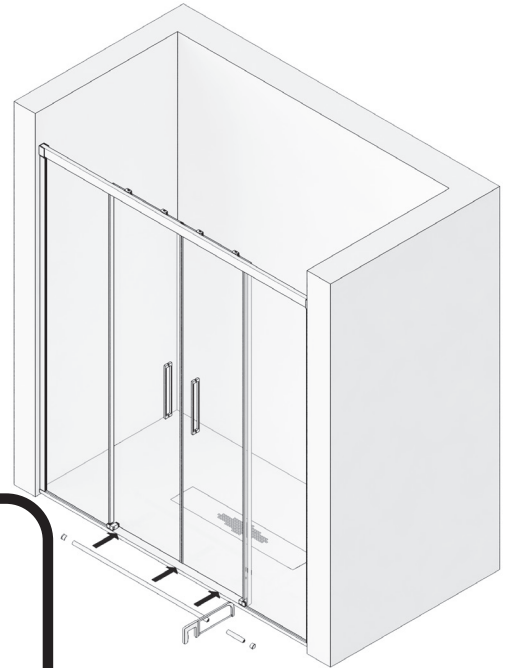

PERFIL DE ESTANQUEIDAD

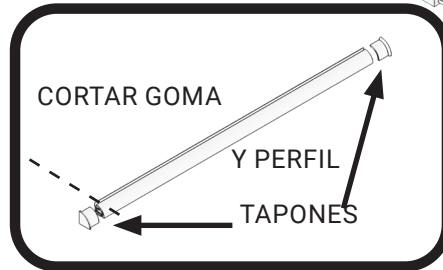

16

SELLAR CON SILICONA EL CONTORNO EXTERIOR DE LA MAMPARA.

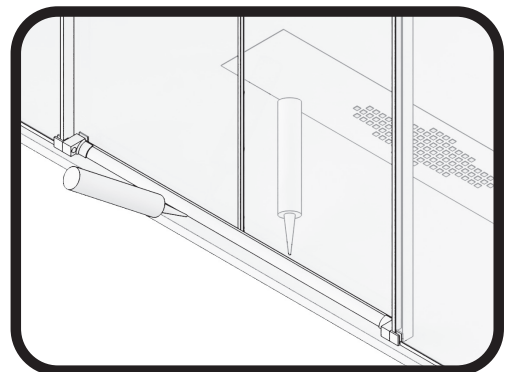

F4

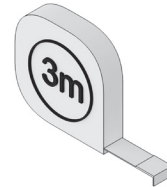
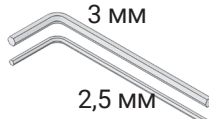
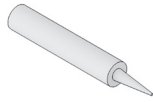
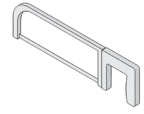
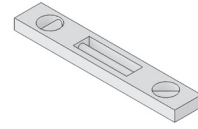
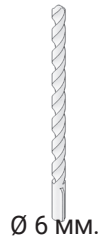
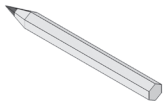

2X

HOJA FIJA



2X

HOJA CORREDERA

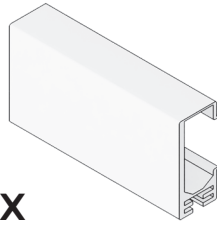

1X

PERFIL GUÍA SUPERIOR

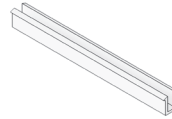

1X

VARILLA GUÍA SUPERIOR

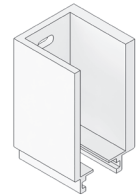

2X

VASO SOPORTE GUÍA

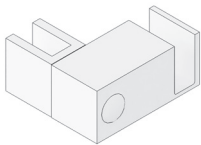

2X

PINZA GUÍA INFERIOR

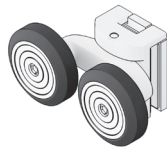

4X

RODAMIENTO INDUSTRIAL SUPERIOR

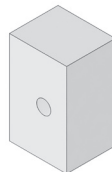

4X

TOPE FRENO



2X

ASA TIRADOR



2X

PERFIL "U" FIJO A PARED

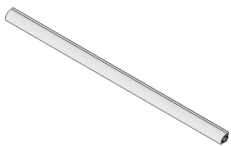

1X

PERFIL DE ESTANQUEIDAD



2X

TAPONES PERFIL ESTANQUEIDAD



1X

GOMA INFERIOR VIERTEAGUAS PUERTA



1X

GOMA ESTANQUEIDAD FIJO

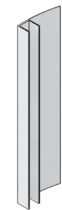

4X

GOMA ALA CRUCE



2X

GOMA CIERRE IMAN FRONTAL



10X

TACOS Nº6

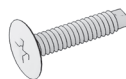

10X

TORNILLOS 4.2 X 32