

MANUAL DE MONTAJE

F3



MAMPARA FRONTAL DE DUCHA

1 HOJA CORREDERA + 2 FIJAS

F3

1

PRESENTAMOS PERFILES "U" DE FIJOS, EN PARED, SEGÚN CORRESPONDA SU POSICIÓN, NIVELÁNDOSLOS, A 3 MM. DEL BORDE DEL PLATO DE DUCHA Y MARCAMOS TALADROS.

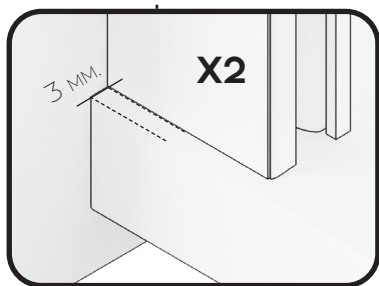
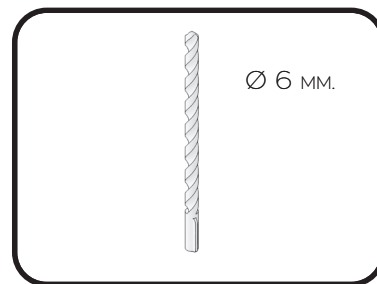

2

TALADRAR LAS PAREDES CON BROCA DE 6MM.

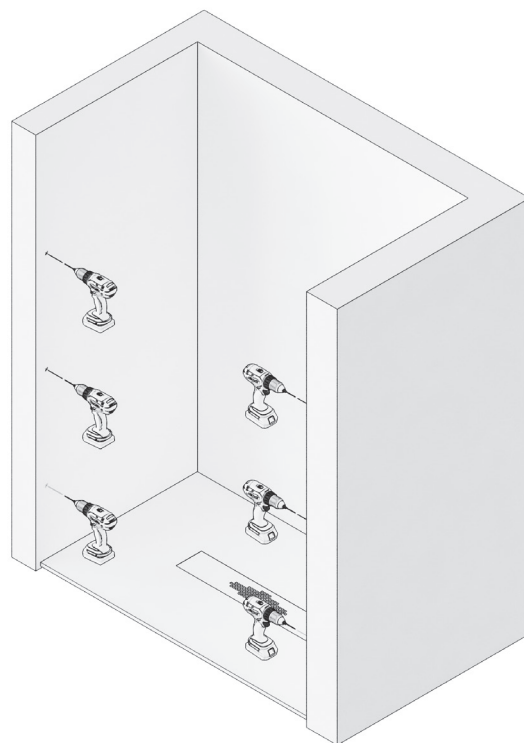

3

ATORNILLAR LOS PERFILES "U" A PAREDES, FIJÁNDOLOS CON TACOS DEL Nº 6 Y LOS 6 TORNILLOS 4.2X32



4

COLOCAMOS LAS GOMAS DE ESTANQUEIDAD INFERIORES EN LAS HOJAS FIJAS E INTRODUCIMOS LOS VIDRIOS EN LAS "U", SEGÚN CORRESPONDA SU POSICIÓN, APOYANDOLOS SOBRE ESTAS.



5

COLOCAR LA PINZA GUIA INFERIOR EN EL EXTREMO DEL VIDRIO FIJO CONTRARIO AL CIERRE, MONTANDOLA PREVIAMENTE SEGÚN CORRESPONDA SU POSICIÓN.



MONTAJE PINZA GUIA INFERIOR

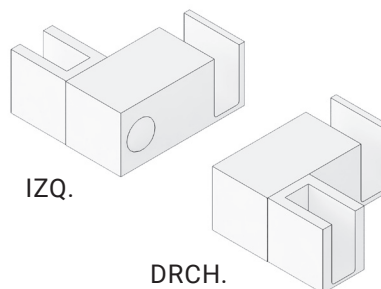
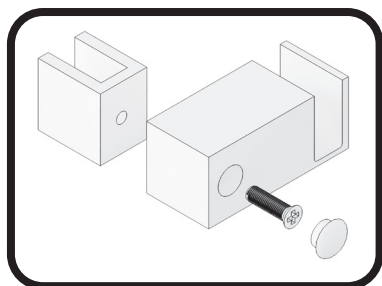

F3

6

PRESENTAR GUÍA SUPERIOR
CON VASOS SOBRE LOS
VIDRIOS FIJOS, NIVELAR Y
MARCAR LOS TALADROS.

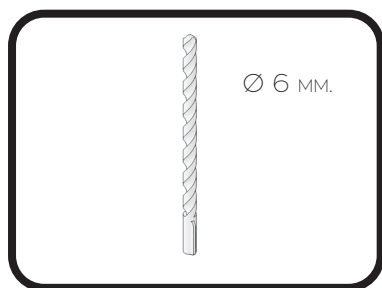
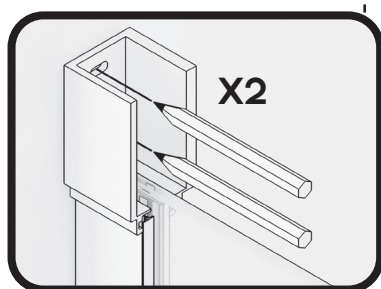

7

TALADRAR LA PARED CON
BROCA DE 6MM.

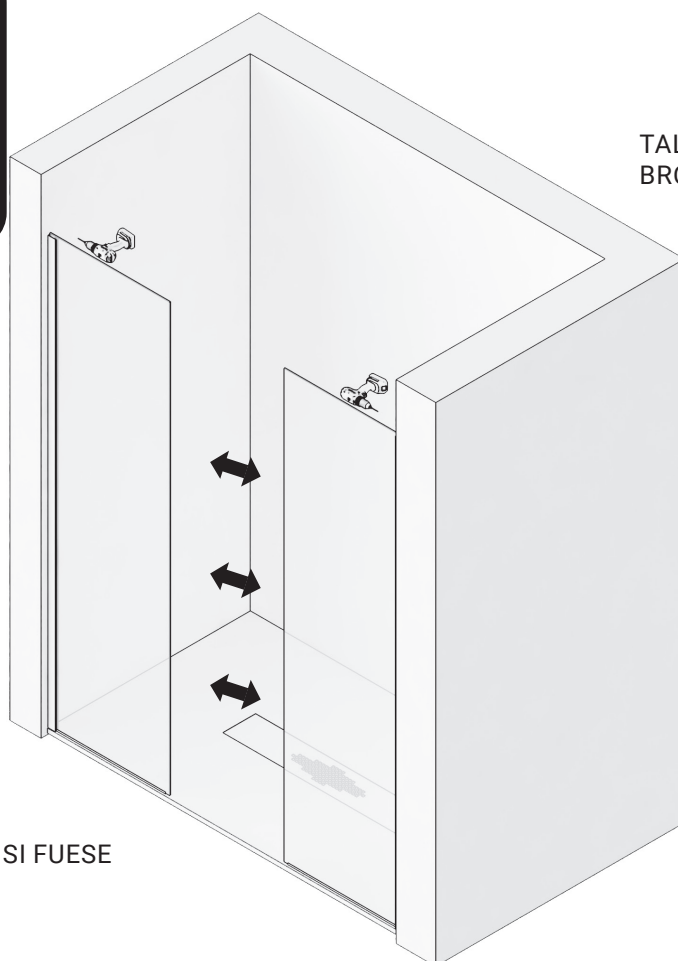

RETIRAR CRISTALES FIJOS SI FUESE
NECESARIO.

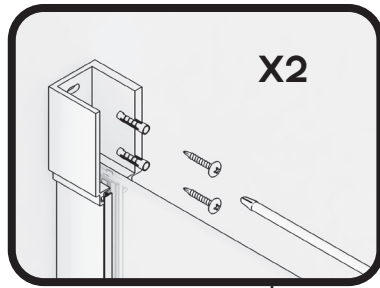

8

ATORNILLAR LOS VASOS SOPORTE
GUÍA SUPERIOR A PARED.



9

INTRODUCIR LOS DOS RODAMIENTOS Y
TOPES DE FRENO EN GUIA SUPERIOR, ASÍ
COMO EL GUARDARRAIL.
CORTAR EL GUARDARRAIL AL ANCHO
DEL HUECO OCUPADO POR LA PUERTA
CORREDERA E INTRODUCIR EN LA GUÍA.

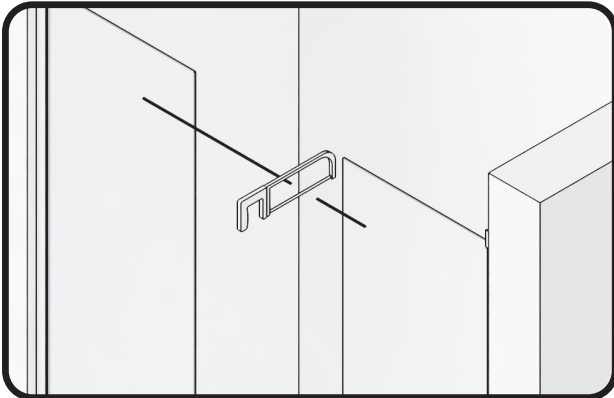
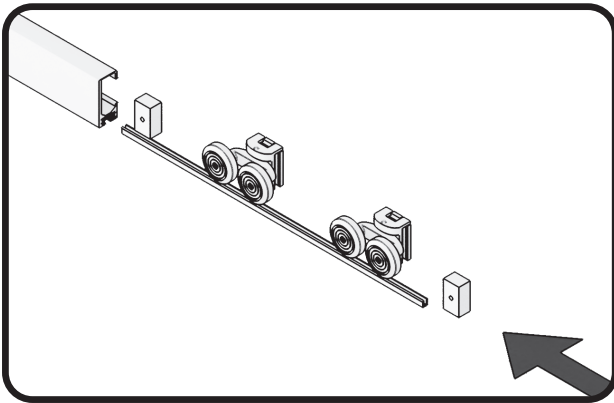

10

COLOCAR LA GUIA SUPERIOR EN LOS VASOS
COGIDA A PARED Y FIJAR LA COGIDA A LA GUIA,
MEDIANTE LOS TORNILLOS PRISIONEROS, CON
LLAVE ALLEN.

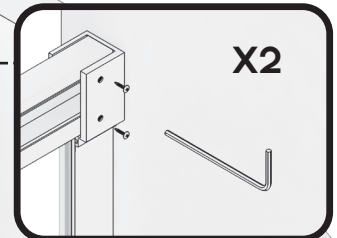
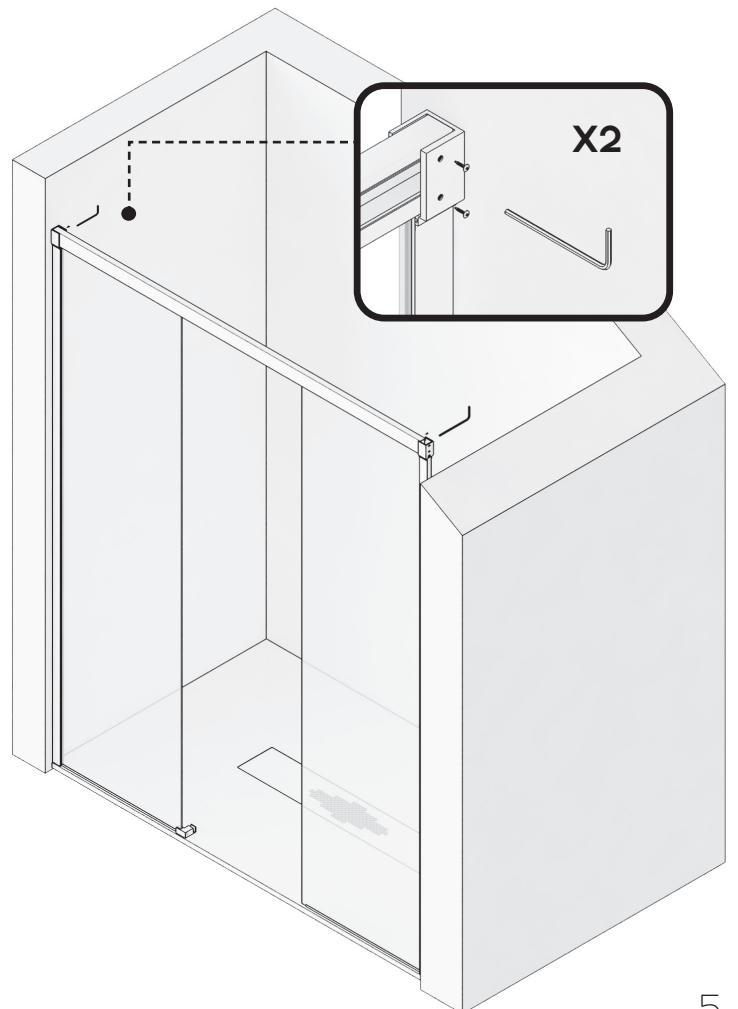

F3

11

COLOCAR PERFIL CIERRE IMAN EN CANTO VIDRIO HOJA FIJA, SEGÚN CORRESPONDA, CON EL ALA IMAN HACIA EL INTERIOR DUCHA.



12

COLOCAR LA GOMA INFERIOR VIERTEAGUAS EN LA HOJA CORREDERA Y MONTARLA EN LOS RODAMIENTOS, INTRODUCIENDO LA MISMA EN LA PINZA GUIA INFERIOR. GRADUAR EN ALTURA Y NIVELAR, FIJÁNDOLA FUERTEMENTE EN SU POSICIÓN.

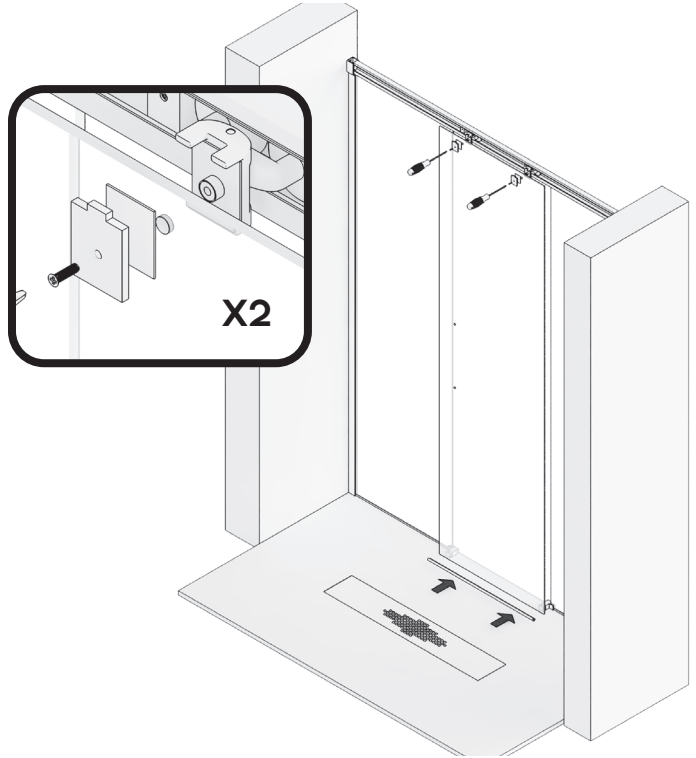

13

COLOCAMOS LAS GOMAS ALA DE CRUCE, UNA EN EL FIJO Y OTRA EN LA HOJA CORREDERA. COLOCAR EL ASA TIRADOR.



14

COLOCAR EL CIERRE GOMA IMAN FRONTAL EN EL CANTO EXTERIOR DE LA HOJA CORREDERA. APROXIMAR LA HOJA CORREDERA AL PERFIL CIERRE IMAN, NIVELÁNDOLO.



15

FIJAR LOS TOPES FRENO EN SU POSICIÓN, MEDIANTE SUS TORNILLOS PRISIONEROS.

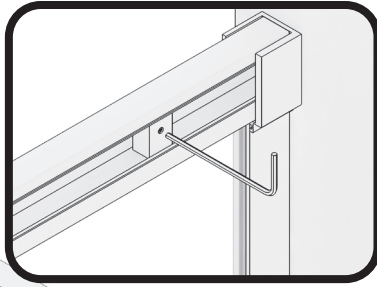

16

MEDIMOS, CORTAMOS, MONTAMOS SUS TAPONES Y PEGAMOS EL PERFIL DE ESTANQUEIDAD, DE PINZA INFERIOR A PARED POR DELANTE DE LA HOJA CORREDERA.

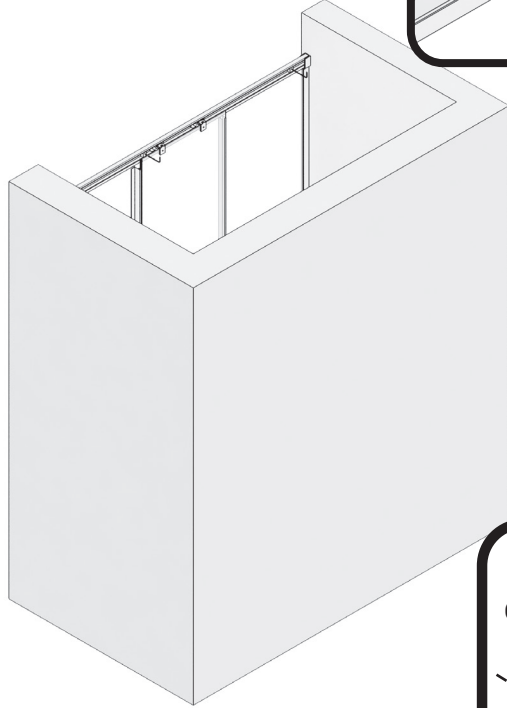

PERFIL DE ESTANQUEIDAD

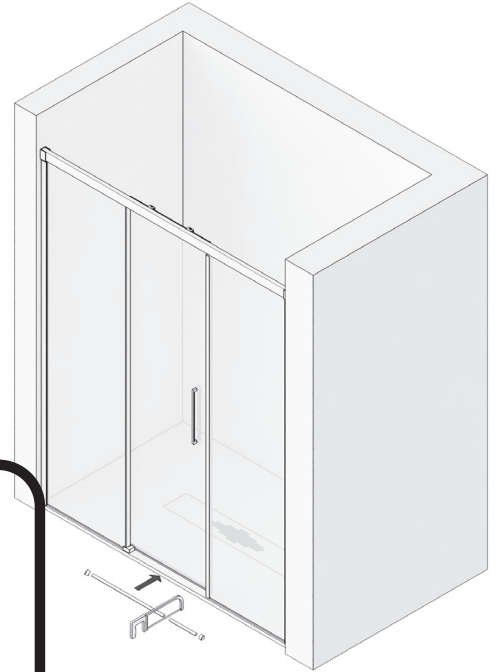
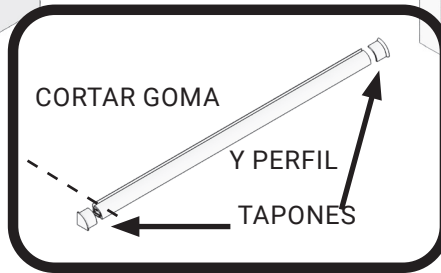





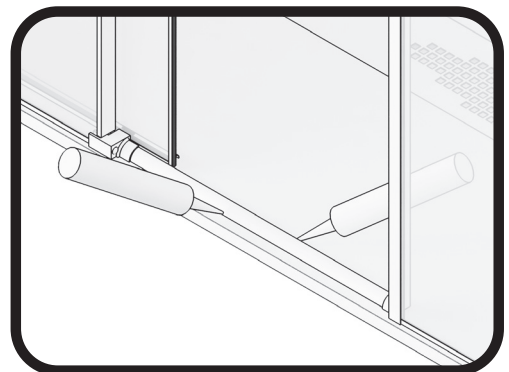



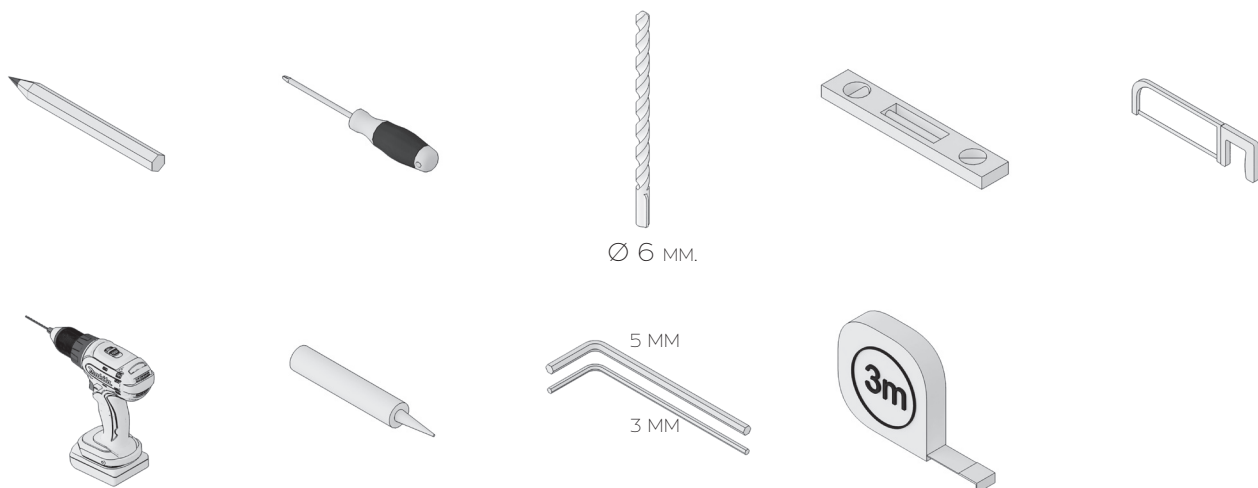

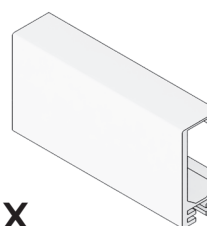
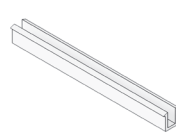
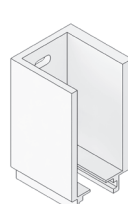
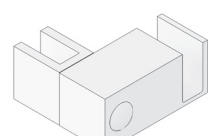
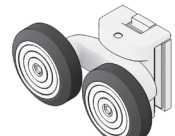
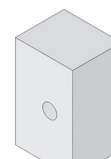

17

SELLAR CON SILICONA EL CONTORNO EXTERIOR DE LA MAMPARA.

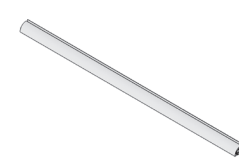

F3

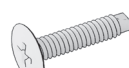

- | | | | | |
|--|--|---|---|---|
| <p>2X</p>  <p>HOJA FIJA</p> | <p>1X</p>  <p>HOJA CORREDERA</p> | <p>1X</p>  <p>PERFIL GUÍA SUPERIOR</p> | <p>1X</p>  <p>VARILLA GUÍA SUPERIOR</p> | <p>2X</p>  <p>VASO SOPORTE GUÍA</p> |
| <p>1X</p>  <p>PINZA GUÍA INFERIOR</p> | <p>2X</p>  <p>RODAMIENTO INDUSTRIAL SUPERIOR</p> | <p>2X</p>  <p>TOPE FRENO</p> | <p>1X</p>  <p>ASA TIRADOR</p> | <p>2X</p>  <p>PERFIL "U" FIJO A PARED</p> |
| <p>1X</p>  <p>PERFIL CIERRE IMAN CENTRAL</p> | <p>1X</p>  <p>PERFIL DE ESTANQUEIDAD</p> | <p>2X</p>  <p>TAPONES PERFIL ESTANQUEIDAD</p> | <p>1X</p>  <p>GOMA INFERIOR VIERTEGUAS PUERTA</p> | <p>1X</p>  <p>GOMA ESTANQUEIDAD FIJO</p> |
| <p>2X</p>  <p>GOMA ALA CRUCE</p> | <p>1X</p>  <p>GOMA CIERRE IMAN FRONTAL</p> | <p>10X</p>  <p>TACOS Nº6</p> | <p>10X</p>  <p>TORNILLOS 4.2 X 32</p> | |