

MANUAL DE MONTAJE

A4



MAMPARA ANGULAR DE DUCHA

2 HOJAS CORREDERAS + 2 FIJAS

PT

A4

1

PRESENTAR "U" EN PARED
Y MARCAR LOS TALADROS
EN AMBOS LADOS.

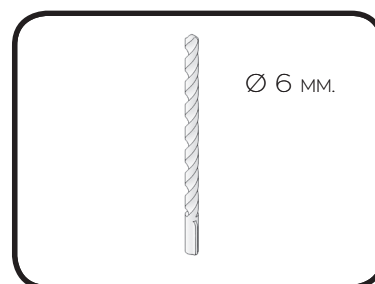
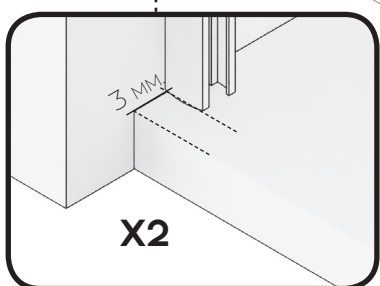

2

TALADRAR CON
BROCA Ø 6 MM



3

ATORNILLAR LA "U" A PARED
USANDO TACOS DE Nº 6
TORNILLOS 4,2 x 32.
EN AMBOS LADOS.

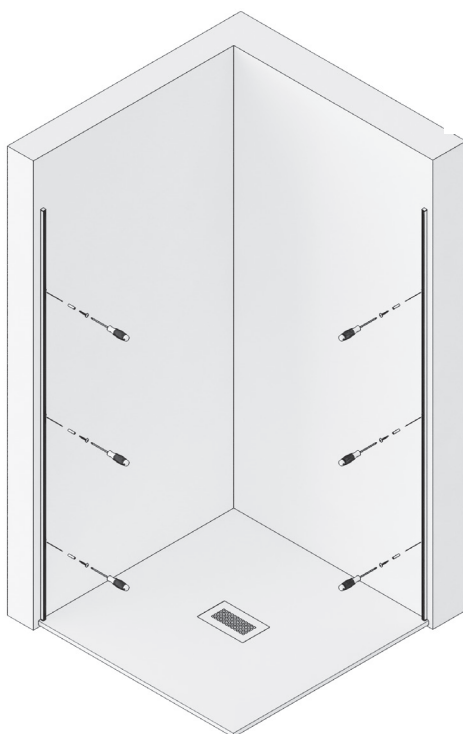

4

COLOCAR GOMAS ESTANQUEIDAD INFERIOR FIJOS E INTRODUCIR LOS CRISTALES FIJO EN LA "U" APOYANDO SOBRE ÉSTA.

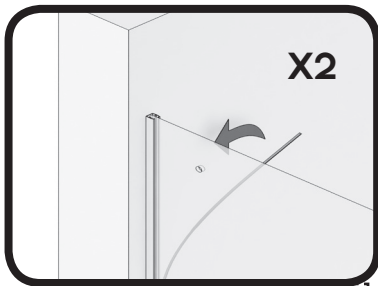

5

ENGOMAR CRISTALES FIJOS A "U" Y COLOCAR LAS PINZAS GUÍA INFERIOR EN LOS EXTREMOS DE LOS VIDRIOS.

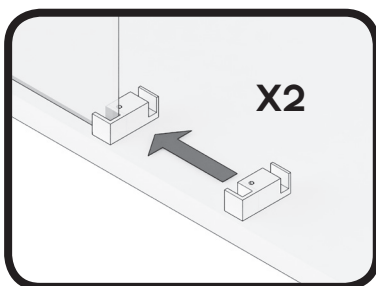

PINZA GUIA INFERIOR

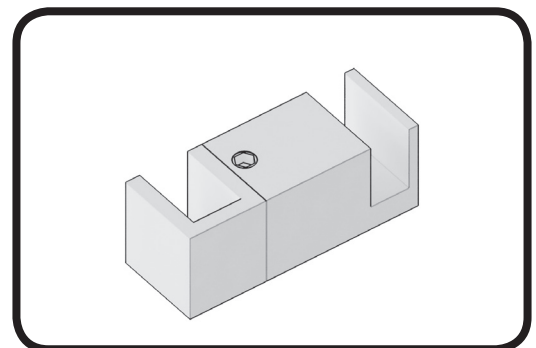

A4

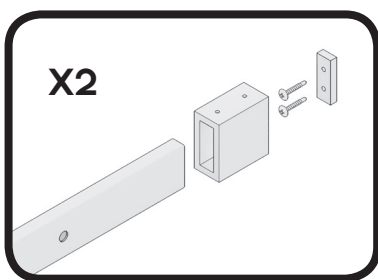
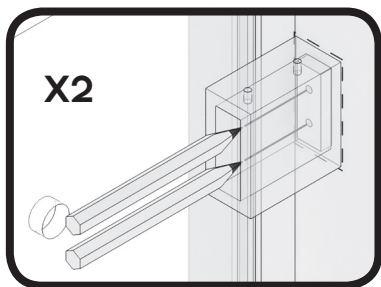

A CONTINUACIÓN DESMONTAR PLACA BASE DEL SOPORTE VASO, SOLTANDO EL TORNILLO PRISINERO, MARCAR TALADROS.

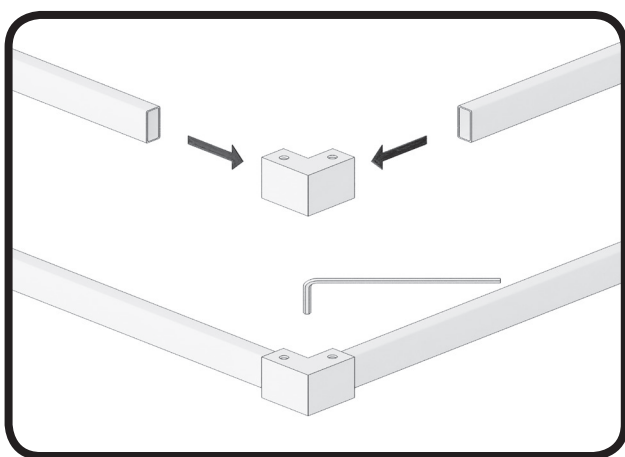

MONTAR CODO UNIÓN GUÍAS.

6

PRESENTAR GUÍAS SUPERIORES CON LOS VASOS. SOBRE LOS VIDRIOS FIJOS, HACIENDO COINCIDIR LOS TALADROS GUIA CON LOS DE LOS VIDRIOS, NIVELAR Y MARCAR LOS CONTORNOS EXTERIORES DE LOS VASOS..



7

TALADRAR CON BROCA DE Ø 6 MM.

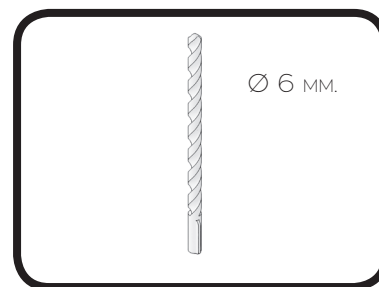

RETIRAR CRISTALES FIJOS SI FUESE NECESARIO..

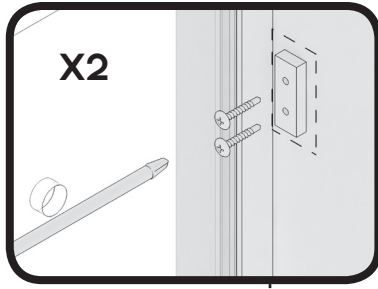

8

ÁTORNILLAR LA PLACA BASE SOPORTE GUÍA SUPERIOR COGIDAS A PARED.

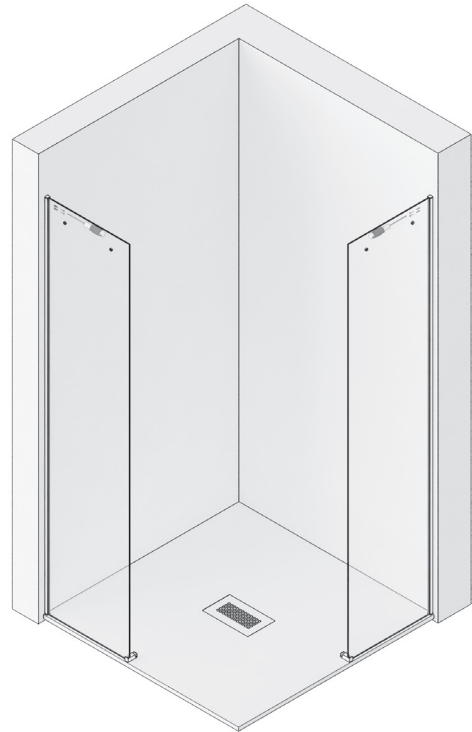

9

INTRODUCIR LOS TOPE FRENO EN LAS GUÍAS. Y LOS VASOS SOPORTE GUÍA.

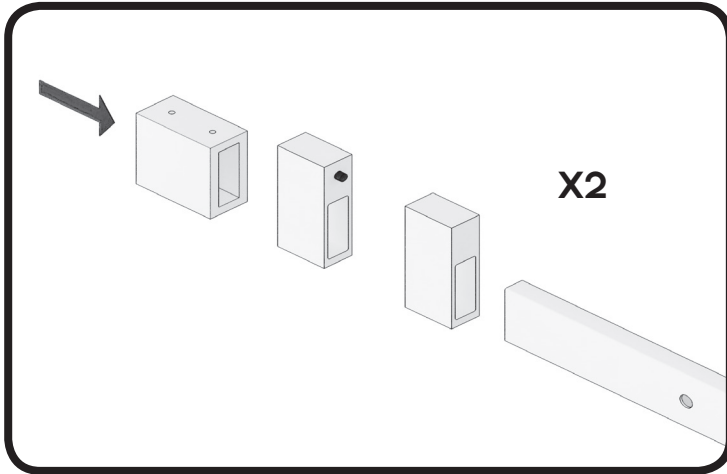

10

COLOCAR LAS GUÍAS SUPERIORES EN LAS BASES COGIDA A PARED, FIJAR LAS COGIDAS A LA GUÍA Y ESTA A LOS TALADROS DE LOS FIJOS CON LAS SUJECIONES.

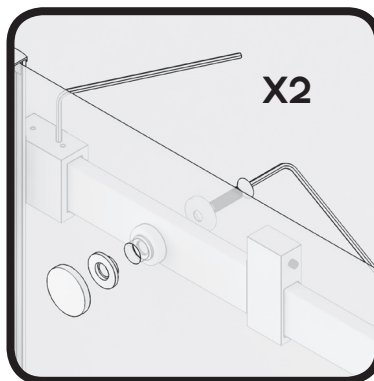

A4

11

COLOCAR LOS RODAMIENTOS EN LAS HOJAS CORREDERAS, COLGAR LAS PUERTAS INTRODUCIENDO PREVIAMENTE LAS GOMAS DE "U" EN LOS CANTOS INFERIORES. GRADUAR RUEDAS..

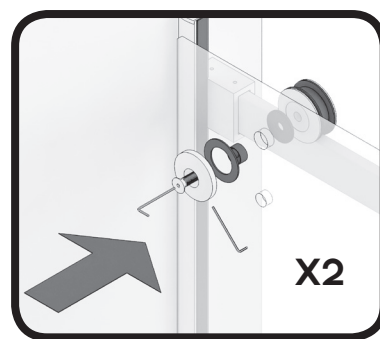
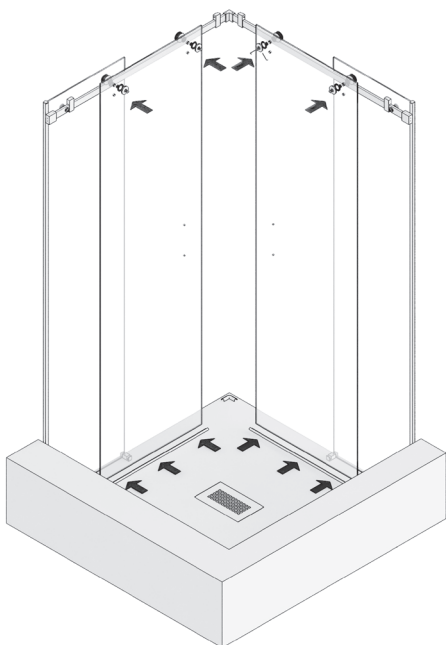

12

MONTAR Y AJUSTAR LOS PERNOS ANTIVUELCO, COLOCAR EL ASA TIRADOR.

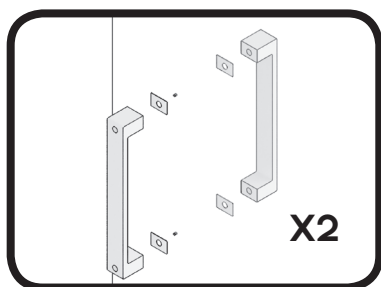
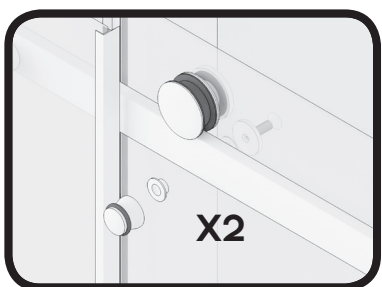

13

COLOCAR LAS GOMAS DE CRUCE, UNA EN LOS FIJOS Y OTRA EN LAS HOJAS CORREDERAS. COLOCAR EL CIERRE GOMA IMÁN EN LOS EXTREMOS DE LA HOJAS CORREDERAS .

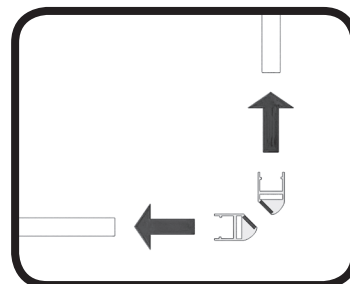
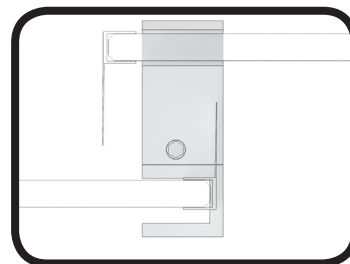
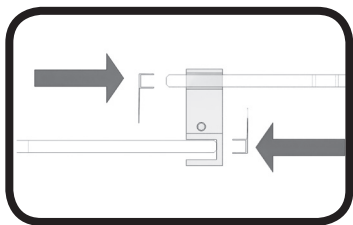

14

FIJAR LOS TOPE FRENO MEDIAN-
TE EL TORNILLO PRISIONERO..

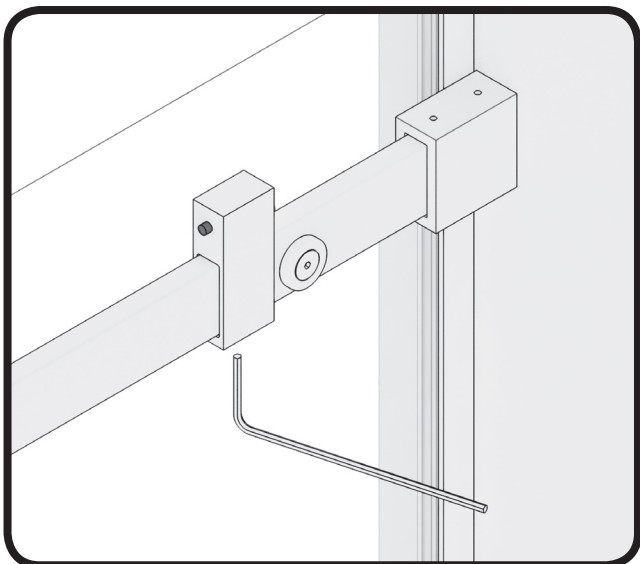

15

CORTAR LOS PERFILES BAJO A MEDIDA. DESDE LA PINZA
BAJA HASTA EL CODO UNIÓN DE LOS FIJOS Y COLOCAR
POR DELANTE DE LAS HOJAS CORREDERAS.

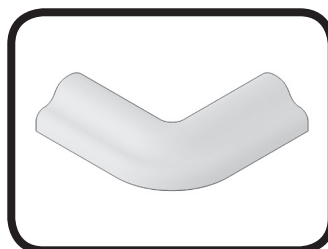

16

PEGAR PERFILES BAJOS CON SILICONA.

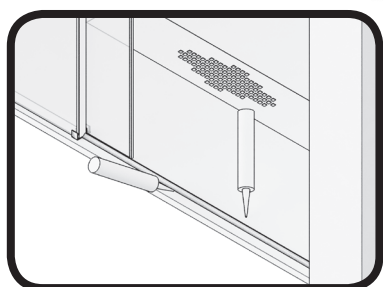

17

SELLAR CON SILICONA
EL CONTORNO EXTERIOR DE LA
MAMPARA.



A4

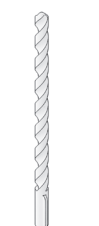
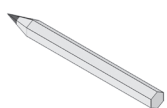

Ø 6 MM.

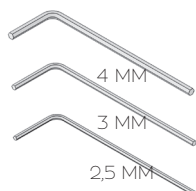
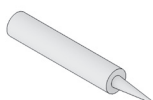
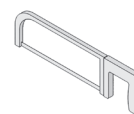
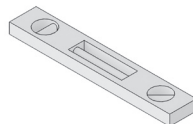

10X

Tacos nº6



10X

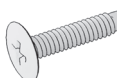

Tornillo 4,2 X 32

2X



HOJA FIJA

2X



HOJA CORREDERA

4X



PERNO ANTIVUELCO

4X

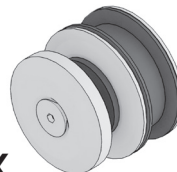

RODAMIENTO SUPERIOR

4X

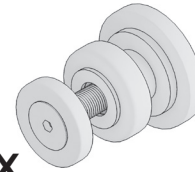

SUJECIÓN FIJO-GUÍA

2X

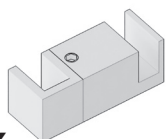

PINZA GUÍA INFERIOR

4X

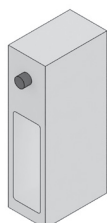

TOPE FRENO

2X

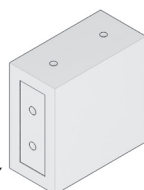

VASO SOPORTE GUÍA

1X

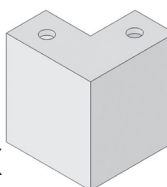

CODO UNIÓN GUÍA

2X

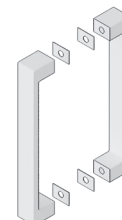

ASA TIRADOR

1X



CODO EMBELLECEDOR INFERIOR

2X



PERFIL "U" FIJO A PARED

2X

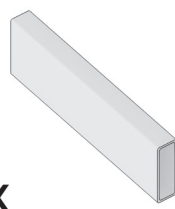

PERFIL GUÍA SUPERIOR

1X



PERFIL VIERTE AGUAS

4X

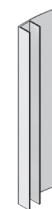

GOMAS DE ALA CRUCE FIJO/CORREDERA

1X



CONJUNTO GOMA IMÁN CIERRE AL VÉRTICE

1X



GOMA ESTANQUEIDAD INFERIOR FIJO

1X



GOMA ESTANQUEIDAD PUERTA INFERIOR

2X



GOMA FIJO "U" Y GUÍA SUPERIOR

2X



TAPA PERFIL CIERRE IMÁN A PARED

fabricación nacional