

MANUAL DE MONTAJE

AP4



MAMPARA ANGULAR DE DUCHA

4 HOJAS PLEGABLES

AP4

1

PRESENTAR LOS PERFILES EXPANSORES DE LAS 1ª PUERTAS, EN PAREDES, NIVELANDOLOS, A 1 CM. DEL BORDE DEL PLATO DE DUCHA Y MARCAMOS TALADROS.

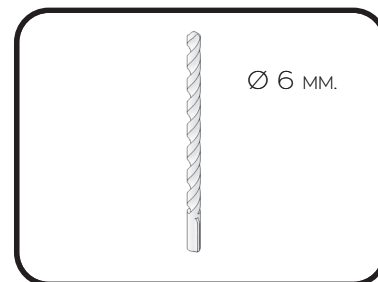
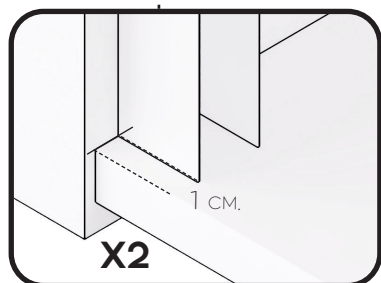

2

TALADRAR LA PARED CON BROCA DE 6MM.

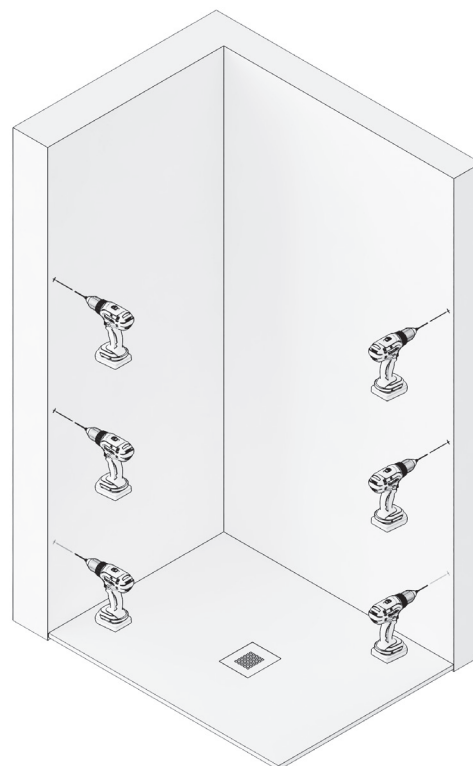

3

ATORNILLAR LOS PERFILES EXPANSORES DE LAS PUERTAS, FIJANDOLO CON TACOS DEL Nº 6 Y LOS 6 TORNILLOS 4.2X32.

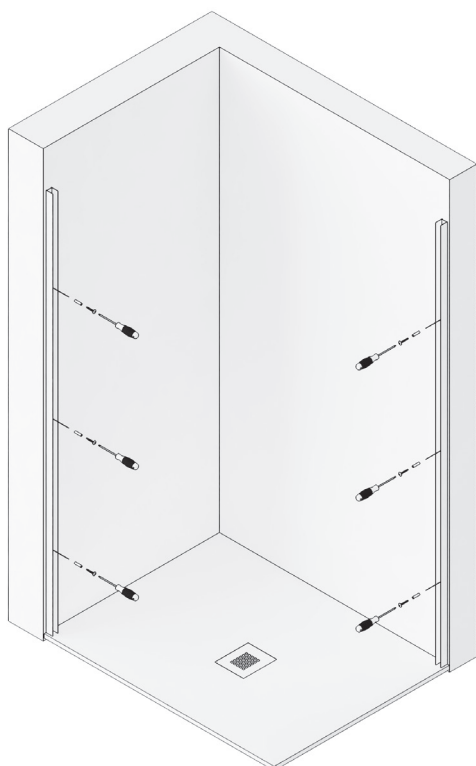

4

INTRODUCIMOS LAS 1ª PUERTAS PRE-MONTADAS EN SUS PERFILES EXPANSORES, CALZANDO LAS MISMAS.



X2

5

UNIMOS LAS 2ª HOJAS PLEGABLES A LAS 1ª HOJAS PRE-MONTADAS, DESMONTANDO LAS BISAGRAS PARA SU ANCLAJE, FIJANDOLA DESPUES, UTILIZANDO UN CALZO PARA SU SOPORTE.

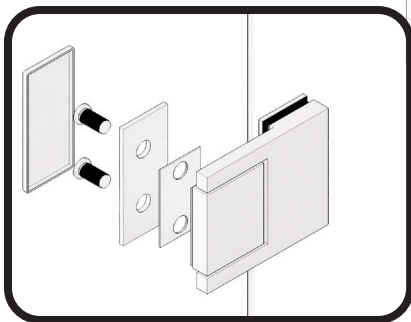

6

MONTAMOS POMOS, GOMAS INFERIORES BARRERA Y GOMAS CIERRE IMÁN ANGULAR, EN LOS EXTREMOS DE LAS 2ª HOJAS ABATIBLES.

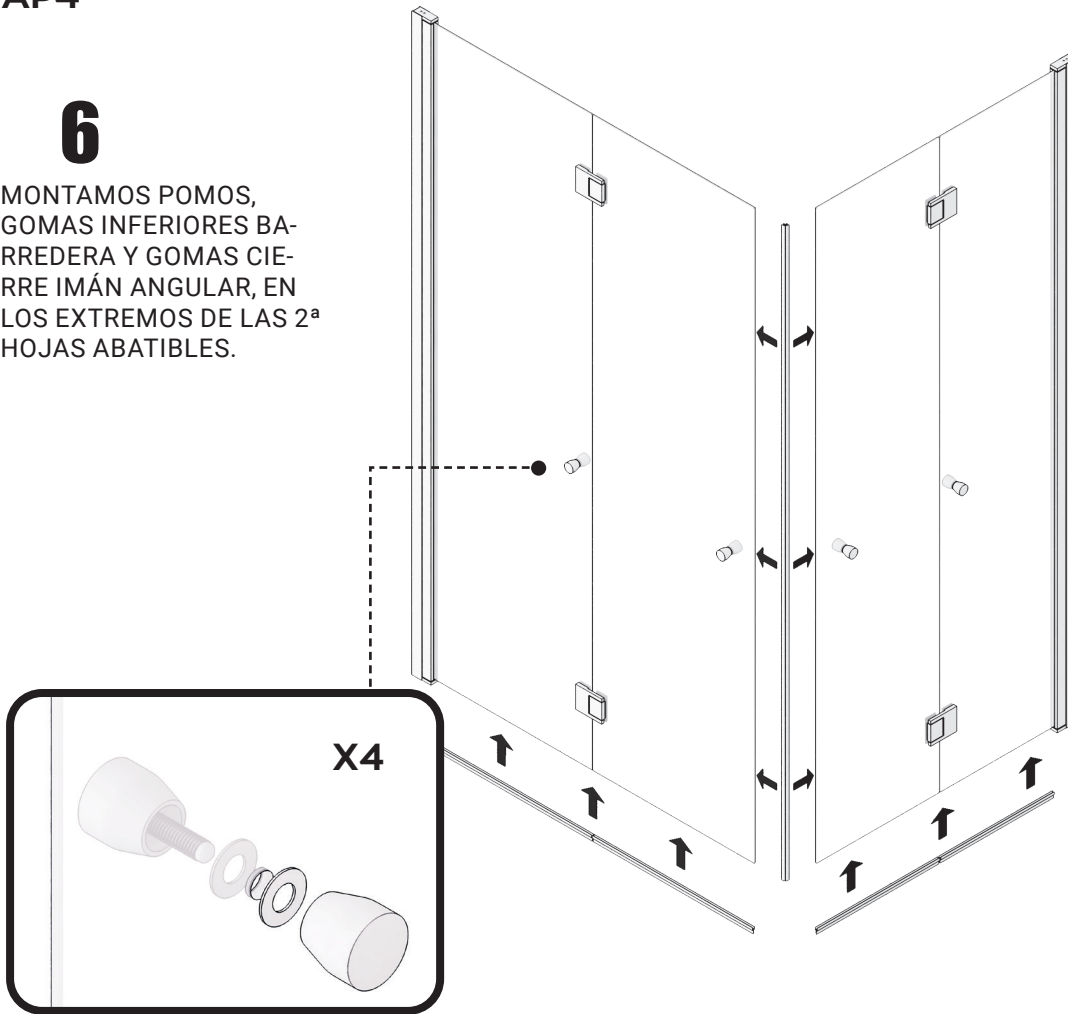

7

APROXIMAMOS Y NIVELAMOS LAS HOJAS PLEGABLES, RESPECTO AL CIERRE AL VÉRTICE. FIJAMOS LAS 1ª HOJAS A LOS PERFILES EXPANSORES, CON LOS 6 TORNILLOS AUTORROSCANTES Y SUS RESPECTIVOS TAPONES, POR EL INTERIOR DE LA DUCHA.

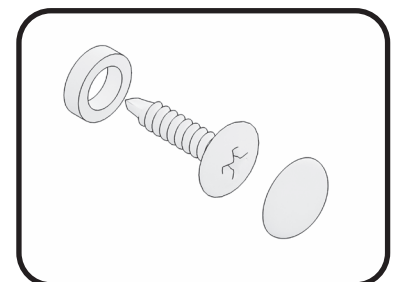
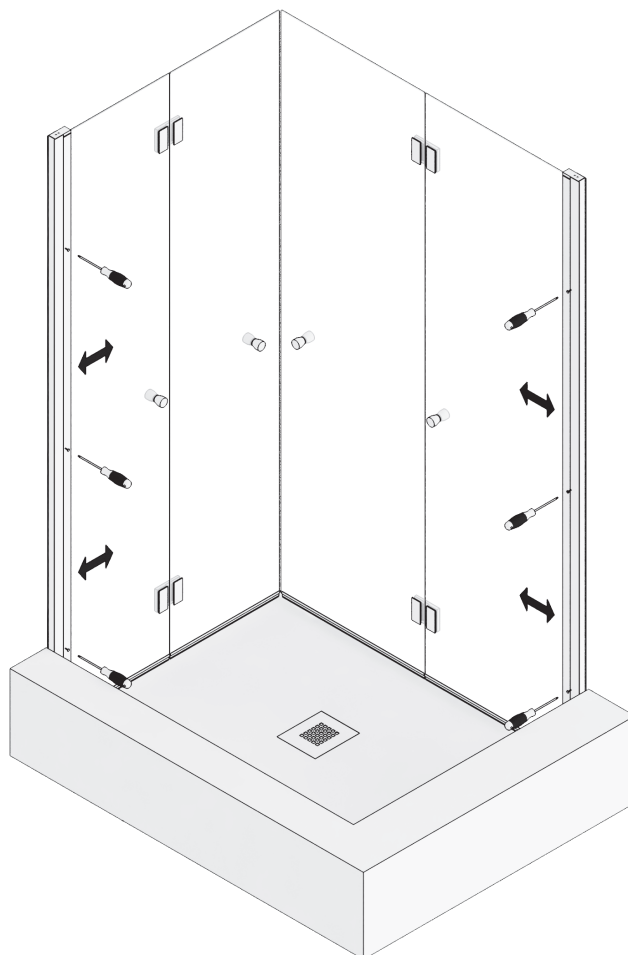

8

MONTAMOS LAS GOMAS ALA ENTRE PUERTAS PLEGABLES, EN LA 1ª PUERTA CON ALA INTERIOR Y EN LA 2ª CON EL ALA EXTERIOR, CAJEANDO LA BASE DE LA GOMA EN SU ENCUENTRO CON LAS BISAGRAS Y GOMAS BARREDERAS, RESPETANDO LAS ALAS, SIN CORTARLAS.

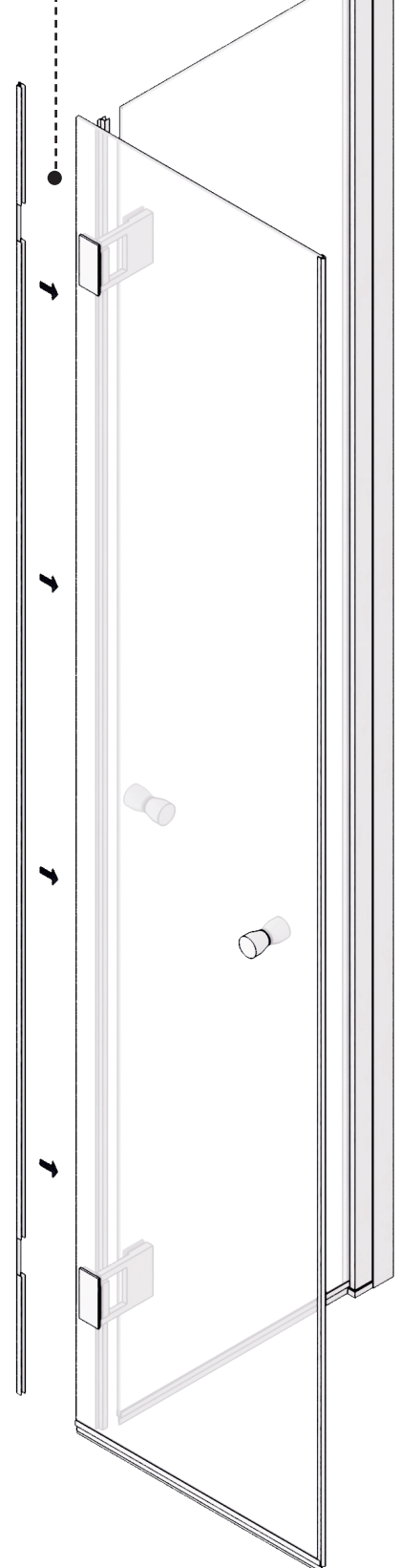
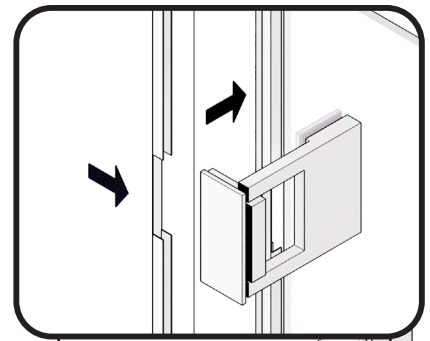
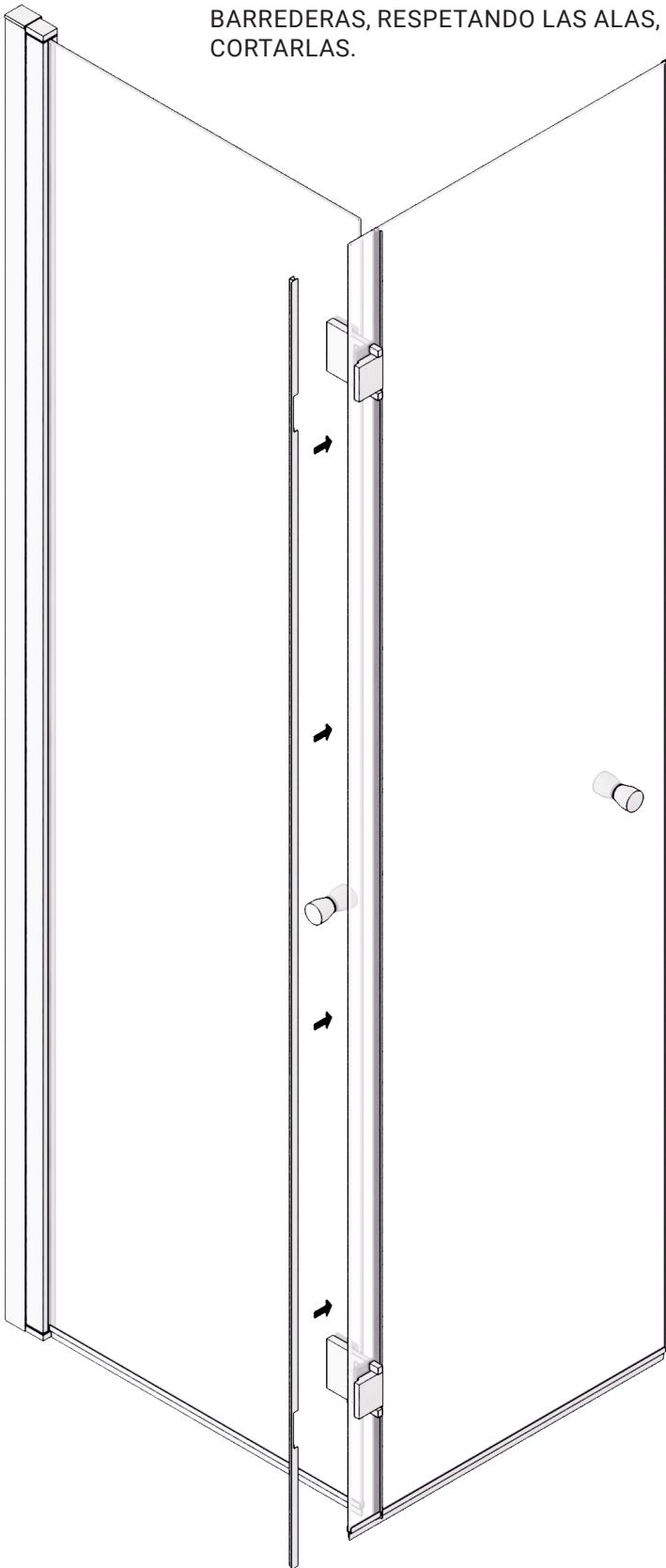

AP4

9

MEDIMOS, CORTAMOS EN ANGULO Y PEGAMOS EL PERFIL DE ESTANQUEIDAD POR DELANTE DE LAS HOJAS PLEGABLES.



10

COLOCAMOS LAS 2 TAPAS EMBELLECEDORAS SUPERIORES EN LOS PERFILES EXPANSORES.

11

SELLAR CON SILICONA EL
CONTORNO EXTERIOR DE
LA MAMPARA



AP4

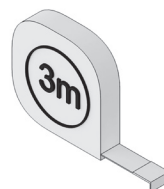
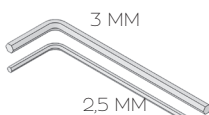
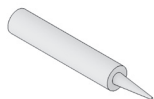
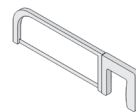
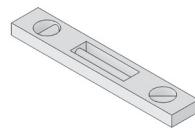
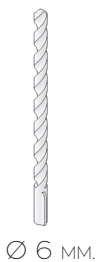
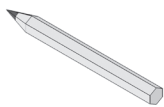

2X



HOJA PLEGABLE 1ª
PRE-MONTADA.

2X



HOJA PLEGABLE 2ª.

2X



PERFIL EXPANSOR 1ª HOJA.

2X

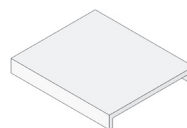

TAPA PERFIL EXPANSOR
1ª HOJA.

1X

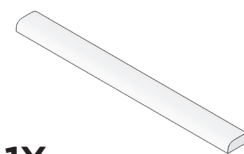

PERFIL DE ESTANQUEIDAD

4X

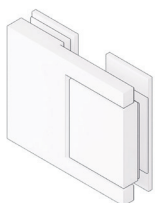

BISAGRAS PLEGABLES
ACERO INOX.

4X



POMOS.

2X



GOMA IMÁN ANGULAR.

1X

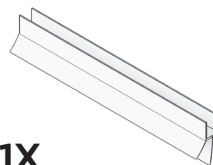

GOMA INFERIOR BARREDERA.

4X



GOMA ALA ESTANQUEIDAD

6X

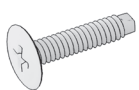

TORNILLOS
AUTORROSCANTES.

6X

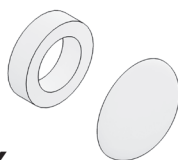

TAPONES CON BASES.

6X

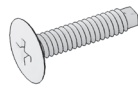

TORNILLOS 4.2 X 32.

6X



TACOS N°6.